

CLINTON SERVICE GUIDE

MODEL 115VS-FOTA-KS

FOR

BROTHER B925

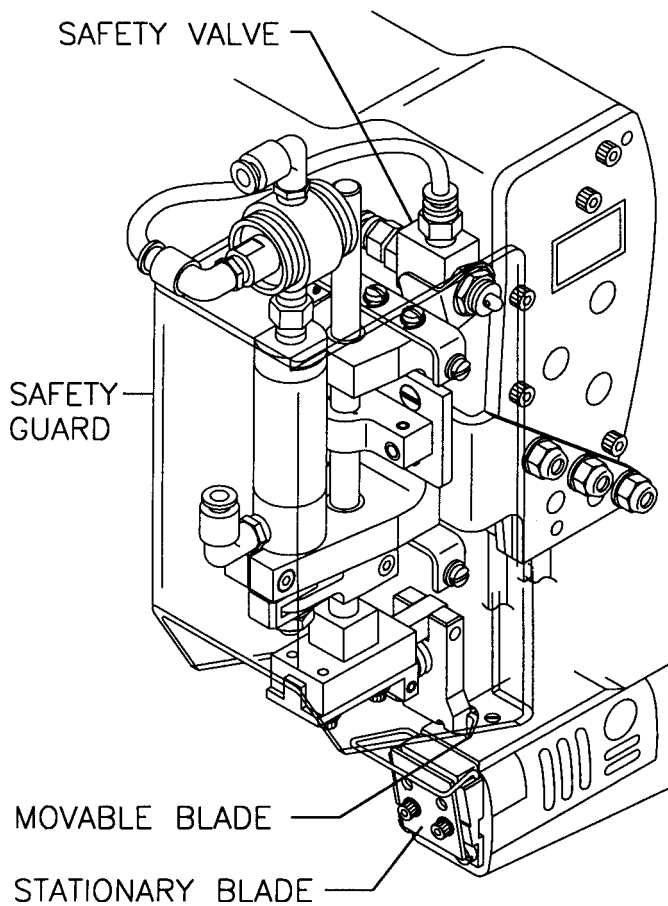

CUTTER ASSEMBLY

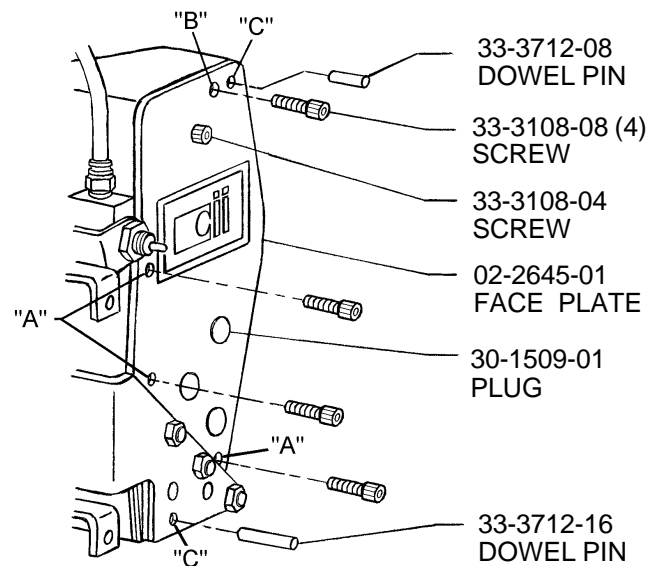

NOTES:

1. REMOVE EXISTING FACE PLATE AND RETAP (3) HOLES MARKED "A" WITH DRILL NO.29 (30-2130-29) AND TAP 8-32 (30-1266-01) SUPPLIED.
2. MOUNT VERTICAL SHEAR CUTTER WITH (3) SCREWS 33-3108-08.
3. DRILL HOLE, MARKED "B" WITH DRILL NO.29 AND TAP 8-32, 5/16 DEEP.
4. USING HOLES MARKED "C" AS A GUIDE, DRILL (2) HOLES 3/16" DIAMETER BY 3/16" DEEP. 3/16" DRILL (30-2376-12) SUPPLIED.
5. INSERT DOWEL PINS (1) 33-3712-08 UPPER SIDE, AND (1) 33-3712-16 LOWER SIDE.



Clinton Industries, Inc.
700 Washington Ave.
Carlstadt, N.J. 07072
Phone: 201-935-4242
Fax: 201-935-3615
www.clintonind.com
E-mail: general@clintonind.com

INSTALLATION & ADJUSTMENTS INSTRUCTIONS

MOVABLE BLADE

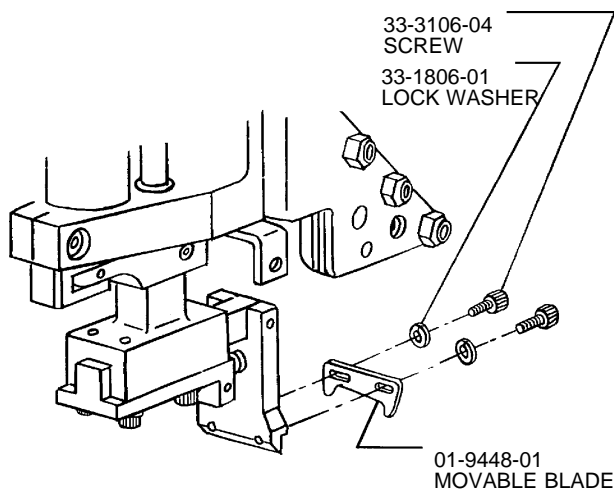

NOTES:

1. ASSEMBLE MOVABLE BLADE 01-9448-01 WITH SCREWS (2) 33-3106-04 AND LOCK WASHERS (2) 33-1806-01.
2. DO NOT TIGHTEN MOVABLE BLADE SCREWS AT THIS TIME. REFER TO ALIGNMENT ADJUSTMENT.

STATIONARY BLADE

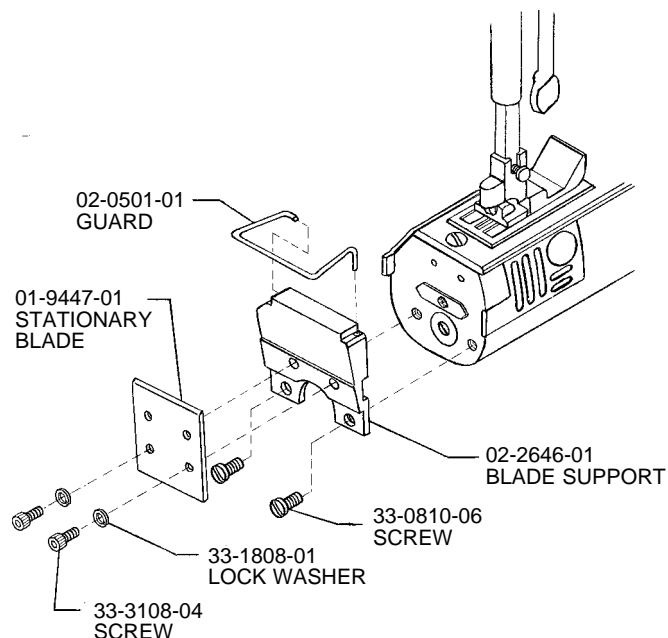

NOTE:

ASSEMBLE STATIONARY BLADE AS SHOWN.

RADIAL

INS-2298

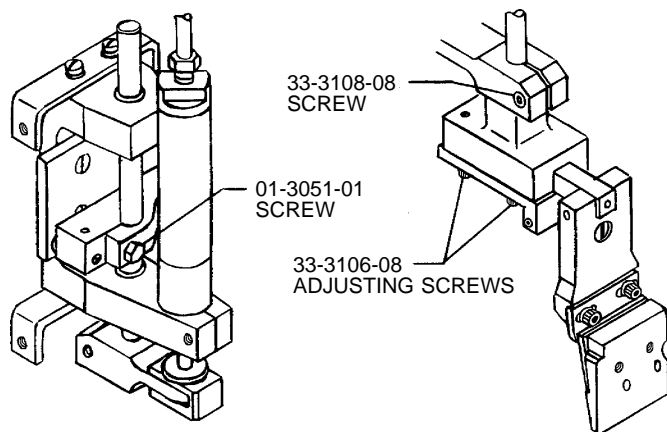

NOTES:

1. LOOSEN SCREW 01-3051-01 AND 33-3108-08 AND ROTATE ASSEMBLY FOR PROPER ENGAGEMENT.
2. LOOSEN SCREWS 33-3106-08 AND ADJUST MOVABLE BLADE AGAINST STATIONARY BLADE AND LOCK IN PLACE.

ALIGNMENT

INS-2299

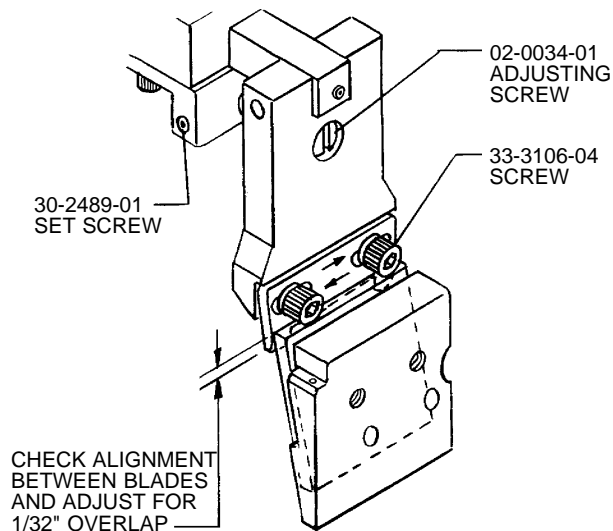

NOTE:

LOOSEN SET SCREW 30-2489-01 AND ADJUST SCREW 02-0034-01 COUNTER-CLOCKWISE FOR MORE CUTTING EDGE ENGAGEMENT.

DRILLING & INSTALLATION INSTRUCTIONS

WARNING!! TO PREVENT SERIOUS INJURY, DISCONNECT AIR SUPPLY BEFORE MAKING ANY ADJUSTMENTS.

DRILL JIG

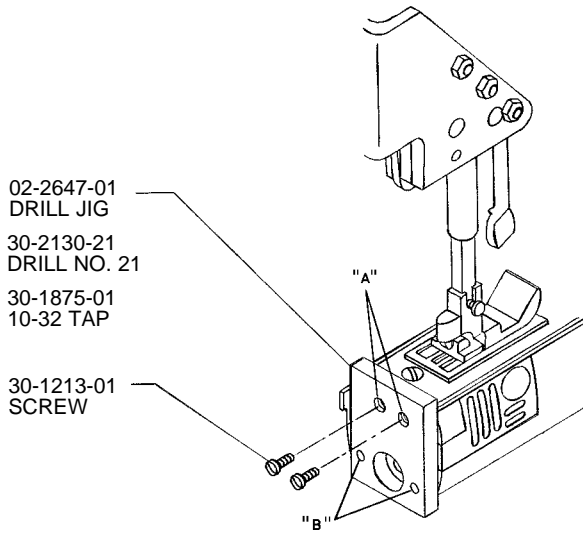

NOTES:

1. FASTEN DRILL JIG 02-2647-01 TO MACHINE USING SCREWS 30-1213-01 SUPPLIED AT POINTS MARKED "A".
2. USING DRILL NO. 21,(30-2130-21) DRILL THE CASTING AT POINTS MARKED "B " 3/8" DEEP. REMOVE THE DRILL JIG AND TAP HOLES AT POINTS MARKED "B" USING THE 10-32, (30-1875-01) TAP SUPPLIED.

FILTER, OILER, REGULATOR & GAUGE ASSEMBLY

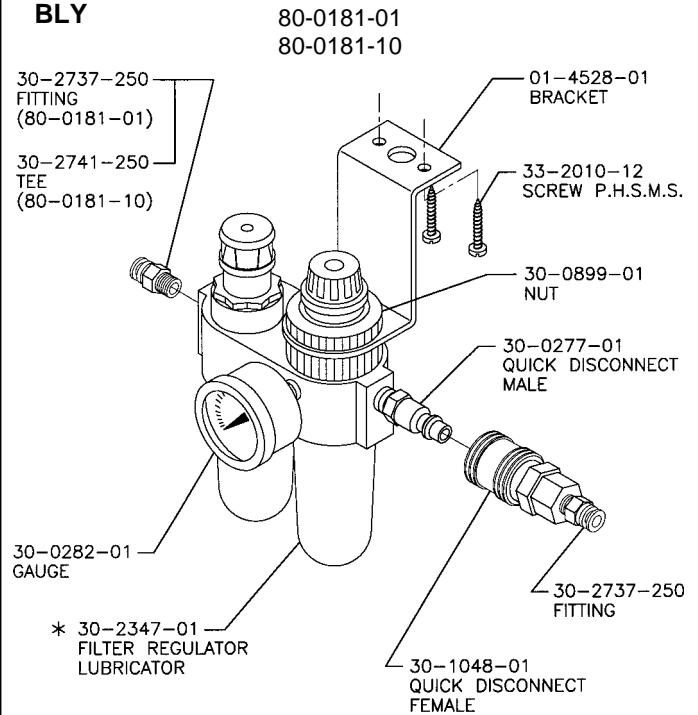

* NOTE: SEE INS-DRAWINGS 2100-1 AND 2100-2 FOR SPARE PARTS

INS-570-3D

AIR CIRCUIT DIAGRAM

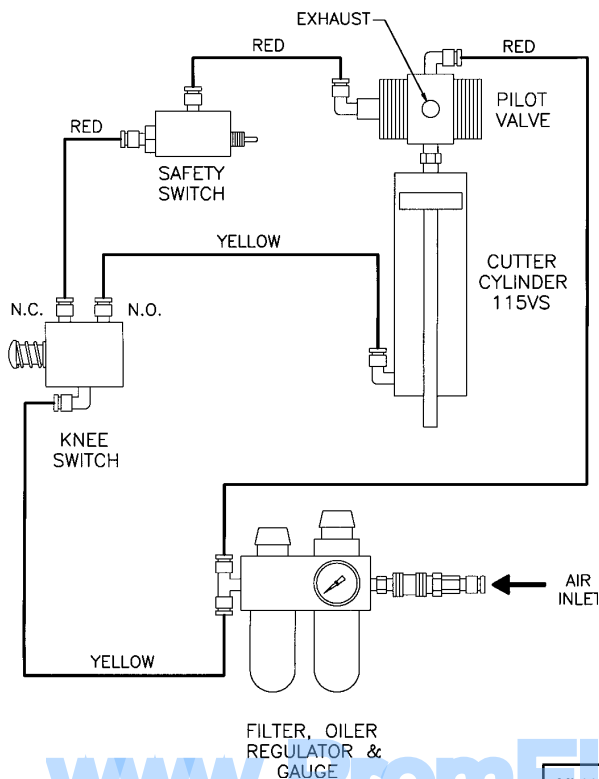

4 WAY AIR VALVE, KNEE OPERATED

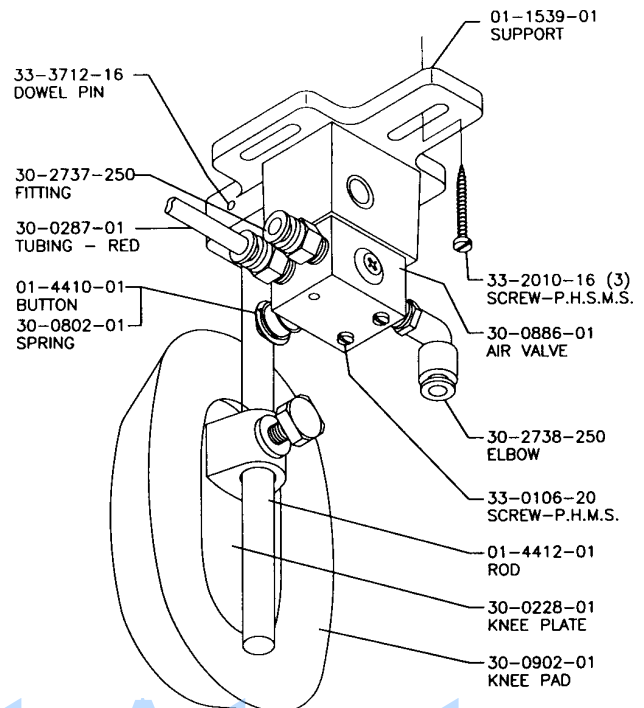

PARTS LIST
MODEL 115VS-FOTA-KS
BROTHER B925
80-0525-03

