

EcoDrive P40 ED

INSTRUCTION MANUAL

Part 3

Parameter list and connection plan

The reprinting, copying or translation of PFAFF Instruction Manuals, whether in whole or in part, is only permitted with our previous authorization and with written reference to the source.

**PFAFF Industriesysteme
und Maschinen AG**

Hans-Geiger-Str. 12 - IG Nord

D-67661 Kaiserslautern

www.promelectroavtomat.ru

List of Contents Part 3

Chapt. Contents	Page
11. Survey and List of Parameters	11.1 - 11.10
11.1 Explanation of Parameter Survey	
11.2 Explanation of Parameter List	
11.3 Parameter Survey	
11.4 List of Parameters	
12. Electrical Connections Diagram	12.1 - 12.4
Appendix adaptor cable	12.5

Technical updatings reserved!

www.promelectroavtomat.ru

11. Survey and List of Parameters

11.1 Explanation of Parameter Survey

The parameter survey is designed as an aid for finding parameters quickly. It is a summary of references for the parameter list. Listed behind each reference are all parameters which exert an influence on the function described by the reference.

The parameter survey is divided into five columns:

Column 1 shows the references (functions) to which parameters are assigned.

Column 2 shows the abbreviations of the respective functions.

Column 3 shows all parameters (setting numbers) belonging to the respective reference.

Column 4 shows, for each function (reference) which controls inputs or outputs, the applicable indications such as Ex or Ax which can also be found on the connections diagram.

Column 5 shows, for each function (control inputs (Ex) or control outputs (Ax)), the respective plugs with the number of contacts (see connections diagram).

Example for searching a parameter:

Keyword (function): inverse rotation

The parameter survey shows in column 3 the parameter numbers 618, 801.

Suppose that the inverse rotation function is to be enabled. The parameter list shows this function under parameter number 618.

11.2 Explanation of Parameter List

The parameter list is divided into 5 columns. These comprise, in

column 1: the parameter number,

column 2: is the explanation (meaning) of the parameters and the coding system of row 1 of the keys of the mini operator's panel, used when the parameter concerned can be programmed with the mini operator's panel,

column 3: the programming level (A, B, C) on which the parameter in question can be accessed,

column 4: the range of values within which the parameter in question can be set,

column 5: the value of the parameter in question is set on delivery ex factory.

Parameters having "either/or" validity (software switches) can merely be set to value I or II. In the case of such parameters, column 4 is empty.

Parameter numbers in acute brackets; e.g. <105>, mean the value (content) set for the parameter in question.

Example:

107 Speed for front backtack when <106> = I

I limited by <105>

II limited by <607>

Explanation:

Parameter 107 is valid only the the value (content) of parameter <106> = I.

If parameter 107 is set to I (<107> = I), then the speed for the front backtack is limited by parameter 105, e.g. <105> = 1500. If parameter 107 is set to II (<107> = II), then the speed for the front backtack is limited by the value of parameter 607, e.g. <607> = 4000.

11.3 Parameter survey P40ED 1_040_14 (PARAM.ENO)

Reference!

All parameters signed with „*“ are retained unchanged after a **Master Reset 1** or **Master Reset 2** has been performed!

Attention! After a **Master Reset 3** all **parameters** are set back to there default values!

With the **control box P40ED**, following machine classes are available:

Maschine class 1 = Pfaff 480 / 910 / 930 / 1180 / 3704 / 5480

Maschine class 2 = Pfaff 570 / 590 / 1570 / 1590 / 335 / 337 / 1240 / 1290

Maschine class 3 = Pfaff 1163

Maschine class 4 = Pfaff 333 - 712

Maschine class 5 = Pfaff 1183 - 712 Speed limited to 1500 rpm

Function	Abbrev'n	Parameter	Input Output	Connection Socket/Contacts
Accelerate	DRZAN	722		
Backtack	RIE	105/107/110 364/391/523 584/585		
Backtack inversion	RIV	748		
Backtack suppression	RIUNT	748		
Blower	BLA	668		
Brake	DRZAB	723		
Catcher	FANG	707		
Chopper	MESSE	105/110		
Clean-cut	CC	793		
Control	REG	815/880/884 885/886/887 889/890/898 900		
Decorative backtack	ZRIE	391/522/523 530/757/775		
Defect search	HWT	797		
Delay	VERZ	623/642/643 730/761/770 793/939/968 969		
Direction of rotation	DRR	800		
Display	ANZ	180/605/933		
Edge trimmer	KS	356/387/776		
End backtack	ER	110/782		

Engine	MOT	897
Feed reverse	TUM	301/364/643 721/793/939 968/969
Front backtack	AR	105/106/107
Hardware test	HWT	797
Inverse rotation	RDR	618/623/801
Linear motor	LINMOT	668
Machine class	MAKL	799
Machine run	ML	387
Needle position	NAPO	522/700/702 703/705/706 707/710/746 748/774
Needle position change-over	NPW	446/748
Needle up without trimming	NHOS	446/710/748
Number of pieces	STUZ	180
Number of stitches	STZA	111/112/470 644/760
ON period	EINZ	528/715/889
Operator panel	BDF	101
Photocell	LS	111/112/113 163/199/615
Piece counter	STUZ	180
Presser foot	PF	356/636/642 651/668/719 729/730/770
Program	PR	203/206/311 313
Programming level C	EBC	798
Residual brake	STBR	718
Seam end	NE	110/206/602
Seam start	NA	105
Single stitch	EST	392/446/748
Soft start	SANL	116/117

Speed	DRZ	105/106/107 110/117/199 203/462/530 585/605/606 607/608/609 782/901
Speed decrease	DRZAB	723
Speed increase	DRZAN	722
Speed limitation	DB	585
Stacker	STAP	528/776
Start	START	113
Start delay	STVERZ	729
Starting block	ANLSP	680
Stitch condensation	STVD	105/106/107 110/364
Stitchcounter	STZ	760
Stop	STOP	206/680/774
Stop time	STOPZ	775
Target stitch	PEIPO	653/789
Thread clamp	FK	470/985
Thread monitor	FW	382/644/660 760
Thread puller	FZ	761
Thread tension release	FSL	393/538/631 636/694/707 761/762/763
Thread trimming	SN	311/609/646 705/706/734 901
Thread wiper	WI	668/715
Time needed to switch on	EINZ	528/715/889
Timing output	TA	538/642/643 705/719/721 734
Units	STUZ	180
Vacuum	SAUG	105/110/356
Zigzag machine	ZZ	746

11.4 List of Parameters P40ED 1_040_14 (PARAM.EN)

No.	Function (Meaning)	Level	Range Values	of Value	Standard Value
101	(BDF) Audible signal of the control panel pushbutton 1 = on 0 = off	A,B,C		ON	Kl. 1, 2, 3, 4, 5
105	(AR/RIE/DRZ/MESSER/NA/SAUG/STVD) Speed for front backtack/ stitch condensation	B,C	0100 - 2000 0100 - 2000 0100 - 2000	1600 700 1200	Kl. 1 Kl. 2 Kl. 3, 4, 5
106	(AR/DRZ/STVD) Speed for front backtack / stitch condensation ON variable (treadle-controlled) OFF constant (corresponding to <105>)	B,C		OFF	Kl. 1, 2, 3, 4, 5
107	(AR/RIE/DRZ/STVD) Speed for front backtack / stitch condensation when <106> = 1 ON limited by <105> OFF limited by <607>	B,C		OFF	Kl. 1, 2, 3, 4, 5
110	(ER/RIE/DRZ/MESSER/NE/SAUG/STVD) Speed for end backtack/ stitch condensation	B,C	0100 - 2000 0100 - 2000 0100 - 2000	1600 700 1200	Kl. 1 Kl. 2 Kl. 3, 4, 5
111	(LS/STZA) Light barrier compensation stitches 1 (stitches from light barrier clear to seam end)	A,B,C	0001 - 0030	8	Kl. 1, 2, 3, 4, 5
112	(LS/STZA) Number of stitches for light barrier fade-out on knit fabrics (according to stitch size)	A,B,C	0000 - 0100	0	Kl. 1, 2, 3, 4, 5
113	(LS/START) Start with light barrier ON when light barrier is dark only OFF also when light barrier is clear	B,C		OFF	Kl. 1, 2, 3, 4, 5
116	(SANL) Soft start stitches	A,B,C	0000 - 0030 0000 - 0030	1 0	Kl. 1 Kl. 2, 3, 4, 5
117	(SANL/DRZ) Speed for soft start stitches	B,C	0030 - 4000 0030 - 4000	1000 400	Kl. 1 Kl. 2, 3, 4, 5
163	(LS) Sewing with photocell ON yes OFF no	B,C		OFF	Kl. 1, 2, 3, 4, 5
180	(STUZ/ANZ) Units displayed ON yes OFF no	A,B,C		OFF	Kl. 1, 2, 3, 4, 5
199	(DRZ/LS) Speed for light barrier compensation stitches	B,C	0300 - 2000	1200	Kl. 1, 2, 3, 4, 5
203	(PR/DRZ) Speed for seam program ON variable (treadle-controlled) OFF constant (corresponding to <221> or <222>)	B,C		ON	Kl. 1, 2, 3, 4, 5
206	(NE/PR/STOP) Interrupt/discontinue seam sections at speed = constant (<203> = II) ON with treadle -2 OFF with treadle 0	B,C		OFF	Kl. 1, 2, 3, 4, 5
301	(TUM) Switch-on voltage of the magnet for transport change-over ON 24V OFF 32V	C		OFF	Kl. 1, 2, 3, 4, 5
311	(PR/SN) Cancellation of stitch count ON with thread cutting OFF without thread cutting	B,C		ON	Kl. 1, 2, 3, 4, 5
313	(PR) Programs are backtack programs (darning programs) ON yes OFF no	A,B,C		OFF	Kl. 1, 2, 3, 4, 5
356	(PF/SAUG/KS) Input is at ON Presser foot OFF Vacuuming	B,C		ON	Kl. 1, 2, 3, 4, 5

364	(RIE/STVD/TUM) Transport change-over means for 1 Back-tack 0 Stitch condensation	B,C		ON Kl. 1, 2, 3 OFF Kl. 4, 5
382	(FW) Switching threshold of the analogue input for the thread monitor	B,C	0000 - 0100 15	Kl. 1, 2, 3, 4, 5
387	(ML/KS) Output (motor run) is active ON With Pedal = 1D (Motor running) OFF With Pedal = 1 (Lower presser foot)	B,C		ON Kl. 1, 2, 3, 4, 5
391	(ZRIE/RIE) Speed for single stitch 1 = on 0 = off	B,C	0200 - 0700 450 0200 - 0700 600	Kl. 4 Kl. 5
392	(EST) Change-over to single stitch via treadle 1 = on 0 = off	B,C		- Kl. 1, 2, 3 OFF Kl. 4 OFF Kl. 5
393	(FSL) Thread tension release after seam end 1 = on 0 = off	B,C		ON Kl. 1, 2, 3 OFF Kl. 4, 5
446	(NHOS/NPW/EST) Input is 1 = needle up without trimming 2 = needle position change-over 3 = single stitch 4 = single stitch with reduced length 5 = backtack inversion 6 = backtack suppression 7 = change-over position 8 = puller lift switched off 9 = change-over needle position step by step, forward 10 = change-over needle position step by step, backward	B,C	0001 - 0010 1	Kl. 1, 2, 3, 4, 5
462	(DRZ) Function of speed control unit ON 2 speeds only n-min (to position +7) and n-max (from position +8) and one needle position OFF 12 speed levels and two needle positions	B,C	0000 - 0001 0 0000 - 0001 1 -	Kl. 4 Kl. 5 Kl. 1, 2, 3
470	(STK/FK/STZA) number of stitches for disabling thread gripper	A,B,C	0000 - 0020 3 0000 - 0020 3 -	Kl. 4 Kl. 5 Kl. 1, 2, 3
522	(NAPO/ZRIE) Needle position when stop occurs during decorative backtack (stitch in stitch) ON position 2 (up) OFF position 1 (down)	B,C		OFF Kl. 1, 2, 3, 4, 5
523	(RIE/ZRIE) Backtack ON decorative backtack (stitch in stitch) OFF standard backtack	A,B,C		OFF Kl. 1, 3, 4, 5 Kl. 2
528	(EINZ/STAP) Duration (ms) of stacker function	B,C	0000 - 2500 120	Kl. 1, 2, 3, 4, 5
530	(DRZ/ZRIE) Speed (max.) for decorative backtack	B,C	0100 - 2000 1000 0100 - 2000 600	Kl. 1, 3, 4, 5 Kl. 2
538	(FSL/TA) Timing of output (thread tension release)	B,C	0010 - 0090 40 0010 - 0090 80	Kl. 1, 2, 3 Kl. 4, 5
584	(RIE) Backtack ON four times OFF double	B,C		OFF Kl. 1, 2, 3, 4, 5
585	(DRZ/DB/RIE) Speed limitation	B,C	0300 - 4800 1000	Kl. 1, 2, 3, 4, 5
602	(NE) Seam end at treadle position ON slightly heeled (-1) OFF fully heeled (-2)	B,C		OFF Kl. 1, 2, 3, 4, 5
605	(DRZ/ANZ) Actual speed in display (<725>) ON yes OFF no	B,C		OFF Kl. 1, 2, 3, 4, 5
606	(DRZ) Speed: level 1 (min.)	B,C	0030 - 0650 180	Kl. 1, 2, 3, 4, 5

607	(DRZ) Speed: level 12 (max.)	B,C	0300 - 6000 5000 Kl. 1 0300 - 3200 3000 Kl. 2 0300 - 5500 4000 Kl. 3 0300 - 1500 1000 Kl. 4 0300 - 1500 1200 Kl. 5
608	(DRZ) Acceleration curve (Pedal characteristic) ON = linear OFF = non linear	B,C	ON Kl. 1, 3, 4, 5 OFF Kl. 2
609	(SN/DRZ) Trimming speed 1	B,C	0060 - 0300 210 Kl. 1 0060 - 0300 180 Kl. 2, 3 0060 - 0300 160 Kl. 4, 5
615	(LS) End recognition when photocell goes ON from light to dark OFF from dark to light	B,C	OFF Kl. 1, 2, 3, 4, 5
618	(RDR) Inverse rotation after seam end ON yes OFF no	B,C	OFF Kl. 1, 2, 3, 4, 5
623	(RDR/VERZ) Delay in start-up time (ms) for inverse rotation	B,C	0000 - 2000 30 Kl. 1, 2, 3, 4, 5
631	(FSL) Angle dependend switching of thread tension release Activation angle parameter 762 De-activation angle parameter 763 1 = on 0 = off	B,C	OFF Kl. 4, 5 - Kl. 1, 2, 3
636	(FSL/PF) thread tension release in conjunction with presser foot ON yes OFF no	B,C	OFF Kl. 1, 2, 3 - Kl. 4, 5
642	(PF/VERZ/TA) presser foot time from switch-on to voltage reduction (cycling)	B,C	0010 - 0150 100 Kl. 1, 2, 3, 4, 5
643	(TUM/VERZ/TA) feed reverse time from switch-on to voltage reduction (cycling)	B,C	0010 - 0150 100 Kl. 1, 2, 3, 4, 5
644	(FW/STZA) Knotting stitches after disabling by bobbin thread monitor ON 1 stitch OFF 2 stitches	B,C	0000 - 0020 0 Kl. 1, 2, 3, 4, 5
646	(SN) Without thread trimmer magnet at seam end ON on OFF off	B,C	OFF Kl. 1, 2, 3, 4, 5
651	(PF) Presser foot with automatic descent on machine stop ON yes OFF no	B,C	ON Kl. 1, 2, 3, 4, 5
653	(PEIPO) Target stitch before sewing ON yes OFF no	B,C	OFF Kl. 1, 2, 3, 4, 5
660	(FW) Bobbin thread monitoring 0 without (= **II*) 1 via a sensor (= **I*) 2 by a stitch count	A,B,C	0000 - 0002 0 Kl. 1, 2, 3, 4, 5
668	(BLA/LINMOT/PF/WI) Thread wiper/thread clearer ON yes OFF no	B,C	OFF Kl. 1, 2, 3, 4, 5
680	(STOP/ANLSP) Signal at input stop/run locking causes (in case of <669> = I) ON discontinuation of the functional sequence OFF interruption of the functional sequence	B,C	ON Kl. 1, 2, 3, 4, 5
694	(FSL) Maximum RPM for angle dependend switching of thread tension release	B,C	0300 - 0800 500 Kl. 4, 5 - Kl. 1, 2, 3

700	(NAPO) Needle position 0 (reference position of the needle)	B,C	0000 - 0255 0 0000 - 0255 10	Kl. 1, 2, 3, 4 * Kl. 5
702	(NAPO) Needle position 1 (needle down)	B,C	0000 - 0255 90 0000 - 0255 15 0000 - 0255 80	Kl. 1 Kl. 2 Kl. 3, 4, 5
703	(NAPO) Needle position 2 (thread take-up lever up)	B,C	0000 - 0255 236 0000 - 0255 230 0000 - 0255 226	Kl. 1, 3 Kl. 2 Kl. 4, 5
705	(NAPO/SN/TA) Needle position 5 (end of trimming signal 1 (magnetic thread trimmer)/clock pulses start of the trimming signal 1)	B,C	0000 - 0255 200 0000 - 0255 140 0000 - 0255 100	Kl. 1, 2, 5 Kl. 3 Kl. 4
706	(NAPO/SN) Needle position 6 (start trimming signal 2 (pneumatic thread trimmer))	B,C	0000 - 0255 136 0000 - 0255 15 0000 - 0255 100 0000 - 0255 80	Kl. 1, 5 Kl. 2 Kl. 3 Kl. 4
707	(NAPO/FSL/FANG) Needle position 9 (thread tension release or thread catcher start)	B,C	0000 - 0255 164 0000 - 0255 195	Kl. 1, 3, 4, 5 Kl. 2
710	(NAPO/NHOS) Needle position 3 (needle up)	B,C	0000 - 0255 184 0000 - 0255 206 0000 - 0255 212	Kl. 1, 2 Kl. 3 Kl. 4, 5
715	(EINZ/WI) Duration (ms) of thread wiper	B,C	0000 - 2000 60	Kl. 1, 2, 3, 4, 5
718	(STBR) Timing of residual brake (0 = brake off)	B,C	0000 - 0100 0 0000 - 0100 7	Kl. 1, 2, 3 Kl. 4, 5
719	(PF/TA) Timing output (lifting presser foot)	B,C	0010 - 0060 40 -	Kl. 1, 2, 3 Kl. 4, 5
721	(TUM/TA) Timing output (feed reverse)	B,C	0010 - 0090 40	Kl. 1, 2, 3, 4, 5
722	(DRZAN) Acceleration ramp 1 gradual 50 steep	B,C	0001 - 0060 50 0001 - 0060 30	Kl. 1, 2, 3 Kl. 4, 5
723	(DRZAB) Brake ramp 1 gradual 50 steep	B,C	0001 - 0060 40 0001 - 0060 27	Kl. 1, 2, 3 Kl. 4, 5
729	(STVERZ/PF) Start delay after lowering presser foot	B,C	0010 - 2000 20 0010 - 2000 120	Kl. 1 Kl. 2, 3, 4, 5
730	(PF/VERZ) Lift delay for presser foot after seam end	B,C	0000 - 2000 0 0000 - 2000 50	Kl. 1 Kl. 2, 3, 4, 5
734	(SN/TA) Timing output (thread trimmer) (0=100% switched on)	B,C	0000 - 0090 10 0000 - 0090 40 0000 - 0090 80	Kl. 1, 4, 5 Kl. 2 Kl. 3
746	(NAPO/ZZ) Needle position for change-over, zick-zack or three-fold-stitch	B,C	0000 - 0255 90 0000 - 0255 20 0000 - 0255 80	Kl. 1 Kl. 2 Kl. 3, 4, 5
748	(NHOS/NPW/EST/RIV/RIUNT/NAPO) Input is 1 = needle up without trimming 2 = needle position change-over 3 = single stitch 4 = single stitch with reduced length 5 = backtack inversion 6 = backtack suppression 7 = change-over position 8 = puller lift switched off 9 = change-over needle position step by step, forward 10 = change-over needle position step by step, backward	B,C	0001 - 0010 5	Kl. 1, 2, 3, 4, 5
757	(ZRIE) Stop position for decorative back tack and parameter 522 = 0 (off 60 ms)	B,C	0000 - 0255 25 -	Kl. 2 Kl. 1, 3, 4, 5



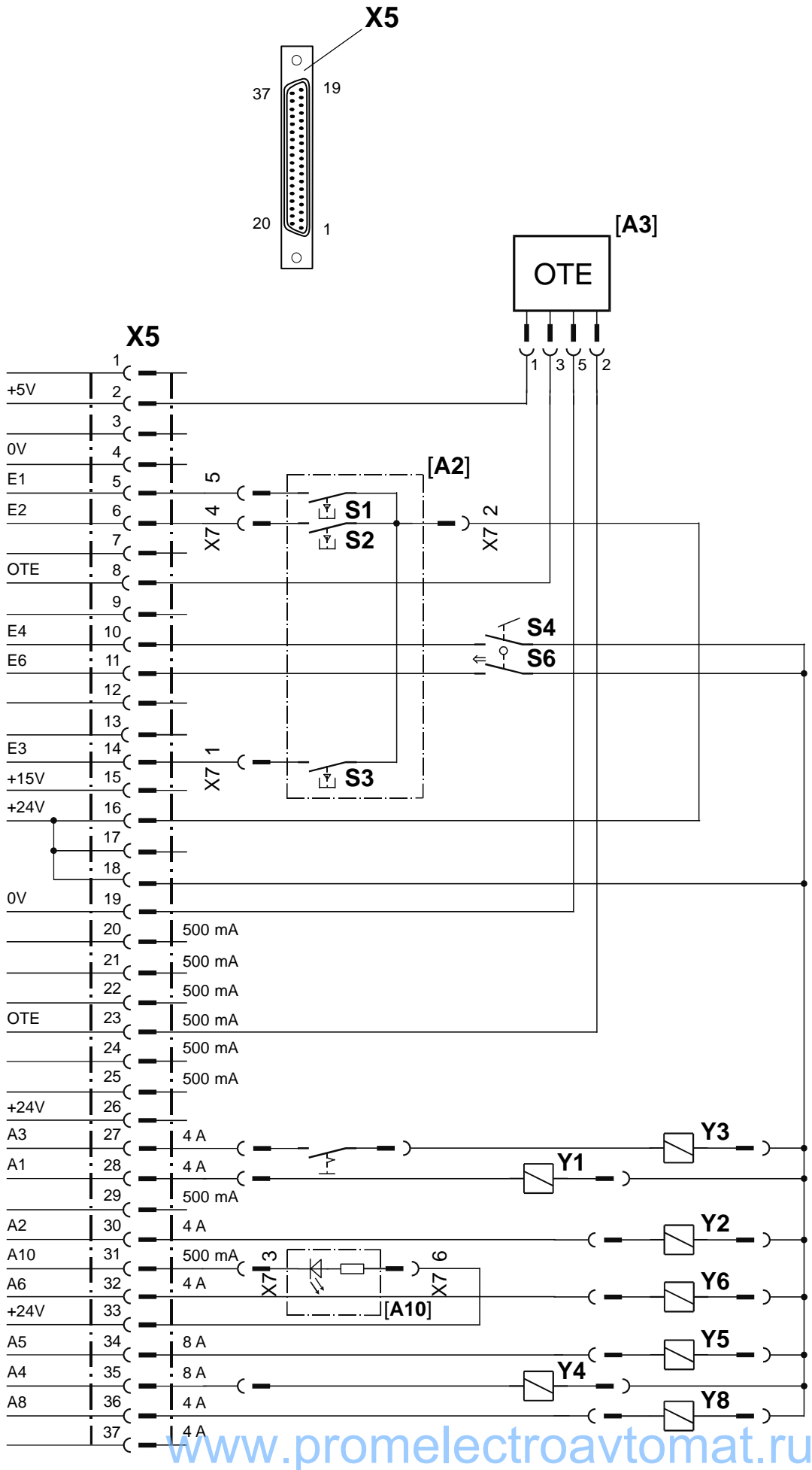

760	(FW/SPFW/STZ/STZA) - Stitch count for the remnant thread after the bobbin thread monitor responds with direct bobbin thread monitoring - Multiplier for the fixed value (200) for determining the start value of the stitch counter with indirect bobbin thread monitoring	A,B,C	0000 - 0250 5	Kl. 1, 2, 3, 4, 5
761	(FSL/FZ/VERZ) Prolongation thread tension release / thread puller	B,C	0000 - 0080 0	Kl. 1, 2, 3, 4, 5
762	(FSL) Switch-on angle for thread tension release	B,C	0000 - 0255 196 -	Kl. 4, 5 Kl. 1, 2, 3
763	(FSL) Switch-off angle for thread tension release	B,C	0000 - 0255 1 -	Kl. 4, 5 Kl. 1, 2, 3
770	(PF/VERZ) Lifting delay of presser foot at threadle- position „-1“	B,C	0010 - 0250 80	Kl. 1, 2, 3, 4, 5
774	(NAPO/STOP) Upper needle position with thick material 1 = needle OT according to <710> 0 = thread take up lever according to <703>	B,C	OFF	Kl. 1, 2, 3, 4, 5
775	(ZRIE/STOPZ) Stop time (ms) with stitch in stitch backtack (decorative backtack)	B,C	0010 - 1000 100 0010 - 1000 150	Kl. 1, 3, 4, 5 Kl. 2
782	(DRZ/ER) Speed reduction before end backtack ON yes OFF no	B,C	OFF	Kl. 1, 2, 3, 4, 5
789	(PEIPO) Needle position 10 (target stitch)	B,C	0000 - 0255 248	Kl. 1, 2, 3, 4, 5
793	(VERZ/TUM/CC) delay (ms) between feeder change enable and cutting for shortened cutting stitch	B,C	0000 - 2000 140 -	Kl. 1 Kl. 2, 3, 4, 5
797	(HWT) Hardware test ON yes OFF no	C	OFF	Kl. 1, 2, 3, 4, 5
798	(EBC) Programming level C ON yes OFF no	A,B,C	0000 - 0020 1	Kl. 1, 2, 3, 4, 5
799	(MAKL) Machine class which has been selected	C	0001 - 0005 1 0001 - 0005 2 0001 - 0005 3 0001 - 0005 4 0001 - 0005 5	Kl. 1 * Kl. 2 Kl. 3 Kl. 4 Kl. 5
800	(DRR) Direction of motor rotation viewed from belt pulley ON left-hand rotation OFF right-hand rotation	C	0000 - 0001 0 0000 - 0001 1	Kl. 1, 5 * Kl. 2, 3, 4
801	(RDR) Reverse rotation angle after seam end	B,C	0010 - 0212 32	Kl. 1, 2, 3, 4, 5
814	(SONST) Positioning change-over 1 = deceleration ramp in target position 2 = Max. braking at positioning speed and waiting until target position is reached.	C	0001 - 0002 1	Kl. 1, 2, 3, 4, 5
815	(REG) Control behavior 1 = control behavior A 2 = control behavior B	C	0001 - 0002 1	Kl. 1, 2, 3, 4, 5
880	(REG) Starting current max. [A]	C	0001 - 0010 5 0001 - 0010 8	Kl. 1, 2, 3 Kl. 4, 5
884	(REG) Proportional amplification of the speed control (in general)	B,C	0003 - 0024 9 0003 - 0030 16 0003 - 0024 10 0003 - 0024 6	Kl. 1, 5 Kl. 2 Kl. 3 Kl. 4
885	(REG) Integral amplification of the speed control	C	0010 - 0080 50 0010 - 0080 23	Kl. 1, 2, 3 Kl. 4, 5
886	(REG) Proportional amplification of the order controllers	C	0001 - 0015 8	Kl. 1, 2, 3, 4, 5

887	(REG) Differential amplification of the order controllers	C	0001 - 0015 8	Kl. 1, 2, 3, 4, 5
889	(EINZ/REG) Time required for order controlling (0 = always)	C	0000 - 2500 200	Kl. 1, 2, 3, 4, 5
890	(REG) Proportional amplification of the superior order controllers for the residual brake	C	0001 - 0025 8	Kl. 1, 2, 3, 4, 5
897	(MOT) MINI motor version ON long OFF short	C	0000 - 0001 0 0000 - 0001 1	Kl. 1, 3, 4, 5 * Kl. 2
898	(REG) Current limiting for the motor 1 = 15A 0 = 10A	C		OFF Kl. 1, 2, 3, 4, 5
900	(REG) Additional P-Amplification of the speed control	B,C	0001 - 0024 10 0001 - 0030 16 0001 - 0024 6 0001 - 0024 9	Kl. 1 Kl. 2, 3 Kl. 4 Kl. 5
901	(DRZ/SN) Trimming release speed	B,C	0030 - 0500 300	Kl. 1, 2, 3, 4, 5
933	(ANZ) Display change-over ON diagnosis OFF normal display	C		OFF Kl. 1, 2, 3, 4, 5
939	(VERZ/TUM) Rate time (premature change-over) for the transport changer when switching on	B,C	0010 - 0200 30	Kl. 1, 2, 3, 4, 5
968	(VERZ/TUM) Rate time for feed reverse during switching off	B,C	0010 - 0200 30	Kl. 1, 2, 3, 4, 5
969	(VERZ/TUM) Switching off angel for presserfoot during thread wiping at seam start	B,C	0000 - 0255 100 -	Kl. 1, 2, 3 Kl. 4, 5
985	(FK) Switch on angle for thread clamp	B,C	0000 - 0255 67	Kl. 1, 2, 3, 4, 5
986	(FK) Switch off angle for thread clamp	B,C	0000 - 0255 206	Kl. 1, 2, 3, 4, 5
989	(FK/FZ/NA) Thread clamp at seam start 0 = Thread clamp off 1 = Thread clamp on 2 = Presserfoot lifting with thread clamp	B,C	0000 - 0002 0	Kl. 1, 2, 3, 4, 5

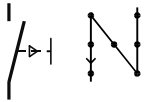
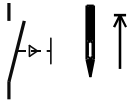

12. Electrical Connections Diagram X5 P40ED

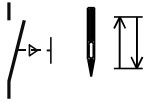
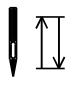
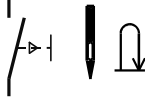
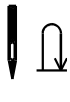
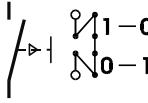
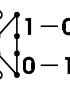
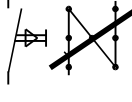

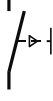
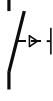
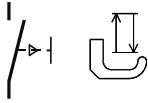
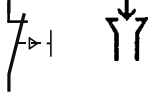
Bedeutung der Magnete bzw. Magnetventile, Taster / Meaning of magnets and/or solenoids and keys
 Signification des aimants resp. solenoides et touches / Significação dos imãs e/ou as solenoidas e teclas
 Significato dei magneti, delle valvole magnetiche e dei tasti / Significación de los imanes y/o los solenoides
 y pulsadores / Betekenis van de magneten resp. magneetkleppen, toetsen

<p>S1 </p>	<p>Transportumstellung von Hand / manual feed reverse / renversement de marche manuel / mudança do transporte manual / commutazione trasporto a mano / inversión de transporte manual / handmatige transportomschakeling</p>
<p>S2 </p> <p>S3 </p> <p>S2 <446> = 1 S3 <748> = 1</p>	<p>Nadel hoch ohne Schneiden / needle up without thread trimming / aiguille en haut sans coupe / agulha para cima sem corte de linhas / ago su senza taglio / aguja arriba sin corte / naald omhoog zonder snijden</p>
<p>S2 </p> <p>S3 </p> <p>S2 <446> = 2 S3 <748> = 2</p>	<p>Nadelpositionswechsel / needle position change-over / changement de position d'aiguille / troca de posição da agulha / cambio di posizione dell'ago / cambio de posición de aguja / naaldpositie-verbisseling</p>
<p>S2 </p> <p>S3 </p> <p>S2 <446> = 3 S3 <748> = 3</p>	<p>Einzelstich / single stitch / point unique / ponto individual / punto singolo / puntada individual / enkele steek</p>
<p>S2 </p> <p>S3 </p> <p>S2 <446> = 5 S3 <748> = 5</p>	<p>Nachfolgende Riegelfunktion invertieren / invert subsequent backtack function / inverser la prochaine fonction de bridage / inverter o próximo remate / invertire la funzione d'affr. successiva / invertir la próxima función de remate / inverteren op elkaar volgende hechtfunctie</p>
<p>S2 </p> <p>S3 </p> <p>S2 <446> = 6 S3 <748> = 6</p>	<p>Riegelunterdrückung / backtack suppression / suppression de bridage / supressão do remate / soppressione dell'afrancatura / supresion del remate / onderdrukking van het strookje</p>
<p>S2 </p> <p>S3 </p> <p>S2 <446> = 7 S3 <748> = 7</p>	<p>Umschaltposition / Change-over position / position le commutation / posição de mudança / posizione di commutazione / posición de cambio / omschakeling position</p>
<p>S4 </p> <p><356> = I</p>	<p>Presserfuß / presser foot / pied presseur / calcador / alzapiedino / prensatelas / drukvoet</p>
<p>S4 </p> <p><356> = II</p>	<p>Saugen / vacuuming / aspiration / aspirar / aspirare / aspirar / zuigen</p>

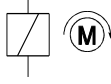
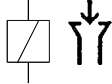
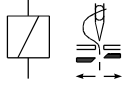
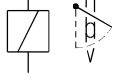
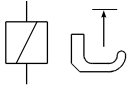
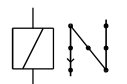
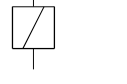
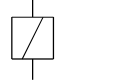
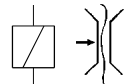
Bedeutung der Magnete bzw. Magnetventile, Taster / Meaning of magnets and/or solenoids and keys
 Signification des aimants resp. solenoides et touches / Significação dos imãs e/ou as solenoidas e teclas
 Significato dei magneti, delle valvole magnetiche e dei tasti / Significación de los imanes y/o los solenoides
 y pulsadores / Betekenis van de magneten resp. magneetkleppen, toetsen

S6 	STOP/Anlaufsperrung / STOP/Safety switch no run / STOP/Verrouillage de remise en marche / STOP/Bloqueio de arranque / STOP/Blocco avviamento / STOP/Bloqueo de repuesta en marcha / STOP/Startblokkering
Y1  I max 4 A * <356> = I	Motorlauf / motor runs / moteur en marche / motor em movimento / motore in moto / motor en marcha / loop van de machine
Y1  I max 4 A * <356> = II	Absaugung / vacuum / aspiration / aspirar / aspirazione / aspiración / zuigen
Y2  I max 4 A *	Fadenschneiden / thread trimmer / coupe-fil / corte de linhas / rasafilo / cortahilos / draadsnijder
Y3  I max 4 A * <989> = 1	Fadenwischer / thread wiper / écarteur de fil / retira-linhas / scartafilo / retirahilos / draadwischer
Y4  I max 8 A *	Presserfuß heben / lifting presser foot / relevage du pied presseur / levantar do calcador / sollevamento del alzapiedino / elevación de prensatelas / drukvoet optillen
Y5  I max 8 A *	Transportumsteller / feed reverse / renversement de marche / mudança do transporte / commutazione trasporto / inversión de transporte / transportomschakeling
Y6  I max 4 A * <776> = 1	Kantenschneider / edge trimmer coupe de bord / corte cantos rasa bordi / corta bordes zoomsnijder
Y6  I max 4 A * <776> = 2	Stapler / stacker / empileur / empilhadeira / impilatore / apiladora / hefapparaat
Y8  I max 4 A *	Fadenspannungslösen / thread tension release / détenteur de fil / soltar tensão da linha / sbloccaggio tendifilo / detensión del hilo / verbreken van de draadspanning
A10 	Signal Unterfadenwächter / signal bobbin thread sensor
[A2]	Tastergehäuse an der Nähmaschine / key case at the sewing machine

Bedeutung der Magnete bzw. Magnetventile, Taster / Meaning of magnets and/or solenoids and keys
Signification des aimants resp. solenoides et touches / Significação dos imãs e/ou as solenoidas e teclas
Significato dei magneti, delle valvole magnetiche e dei tasti / Significación de los imanes y/o los solenoides
y pulsadores / Betekenis van de magneten resp. magneetkleppen, toetsen

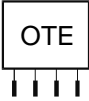
[A3] 	Oberteilerkennung / sewing machine identify unit
---	--

- * Die Summe der Lastströme aller gleichzeitig eingeschalteten Stellglieder (Magnete, Magnetventile) darf den Wert von 4A nicht überschreiten (siehe hierzu Kapitel 2. Technische Daten).
- * The total of load currents of all servos activated simultaneously (solenoids, solenoid valves) is not allowed to exceed 4 amps (see also section 2. Technical Specifications).
- * Le total des courants de charge de tous les vérins (aimants, électro-vannes) activés simultanément ne doit pas dépasser 4 A (voir aussi le chapitre 2. "caractéristiques techniques").
- * A soma das correntes sob carga de todos os actuadores ligados ao mesmo tempo (ímans, solenóides) não pode ultrapassar o valor de 4A (ver também capítulo 2. Dados Técnicos).
- * La somma delle correnti di carico di tutti gli attuatori inseriti contemporaneamente (magneti, elettrovalvole) non deve essere superiore a 4 A (vedere il capitolo 2. Dati Tecnici).
- * La suma de las corrientes bajo carga de todos los elementos de todos los componentes de regulación conectados simultáneamente (imanes, válvula magnética) no podrá sobrepasar el valor de 4A (véase también el capítulo 2. de datos técnicos).
- * De belastingsstroom van alle tegelijkertijd ingeschakelde bedieningsschakels (magnetten, magneetventielen) mag in totaal niet meer dan 4 A bedragen (zie hiervoor hoofdstuk 2. Technische gegevens).

Appendix adaptor cable

Important Notice!

Your newly purchased **EcoDrive** control system is designed to be connected to a sewing machine/system via connector X5. This connector X5 is a 37 pole sub-d jack as shown in the wiring diagram.

*The connections/wiring of X5 is **not identical nor compatible** with the connections of the same type of jack X5 of the **Ministop control box**, nor with the same type of 37 pole sub-d jack of a **Servo control box**!*

In order to avoid damage to the control box, you may only connect the **EcoDrive** to machines wired according to VDMA Regulations

EN 60204-31

If you wish to replace a Ministop or Servotop control box with an EcoDrive, you must either use the appropriate adapter cable or rewire your machine!

We offer following adapter cables:

Replacement for Q40MS:	Q40ED with adapter	Art.-No. 55.591
Replacement for P40/51/52/47 MS	P40ED with adapter	Art.-No. 55.592
Replacement for PE40MS	PE40ED with adapter	Art.-No. 55.580
Y-Adapter for synchronizer (position control unit)		Art.-No. 55.570
Extension cable for synchronizer (position control unit) 1,5m		Art.-No. 55.506
Extension cable for speed control unit 1,5m		Art.-No. 55.507
Extension cable for operator panel EcoTop 5m		Art.-No. 55.573
Serial data cable for Q-Prog		Art.-No. 55.577



Europäische Union
Wachstum durch Innovation – EFRE

PFAFF Industriesysteme und Maschinen AG

Hans-Geiger-Str. 12 - IG Nord
D-67661 Kaiserslautern

Phone: +49-631 200-0
Fax: +49-631 17202
E-mail: info@pfaff-industrial.com

Hotlines:

Technical service: +49-175/2243-101
Application consultancy: +49-175/2243-102
Spare-parts hotline: +49-175/2243-103

Printed in Germany