



Данную детализировку для вас
предоставила компания **Крунз**

PARTS BOOK

KM-813

High Post Bed, Single Needle Drop
Feed Lock Stitch Machine

KM-823

High Post Bed, Twin Needle Drop
Feed Lock Stitch Machine





CONTENTS

목 차

A	<i>Machine Body & Thread Mechanism</i> 외장 및 실장력 조절 관계.....	4
B	<i>Upper Shaft & Needle Bar Mechanism</i> 상축 및 바늘대 관계	6
C	<i>Presser Foot & Knee Lifting Mechanism</i> 누름대 및 무릎올림 관계	8
D	<i>Feed Mechanism</i> 피이드 관계	10
E	<i>Upright Shaft & Lower Shaft Mechanism</i> 입축 및 하축관계	12
F	<i>Post Mechanism</i> 포스트 관계	14
G	<i>Accessories</i> 액세서리 관계.....	16
H	<i>Gauge Parts</i> 게이지 관계	17

Machine Body & Thread Mechanism 외장 및 실장력 조절관계

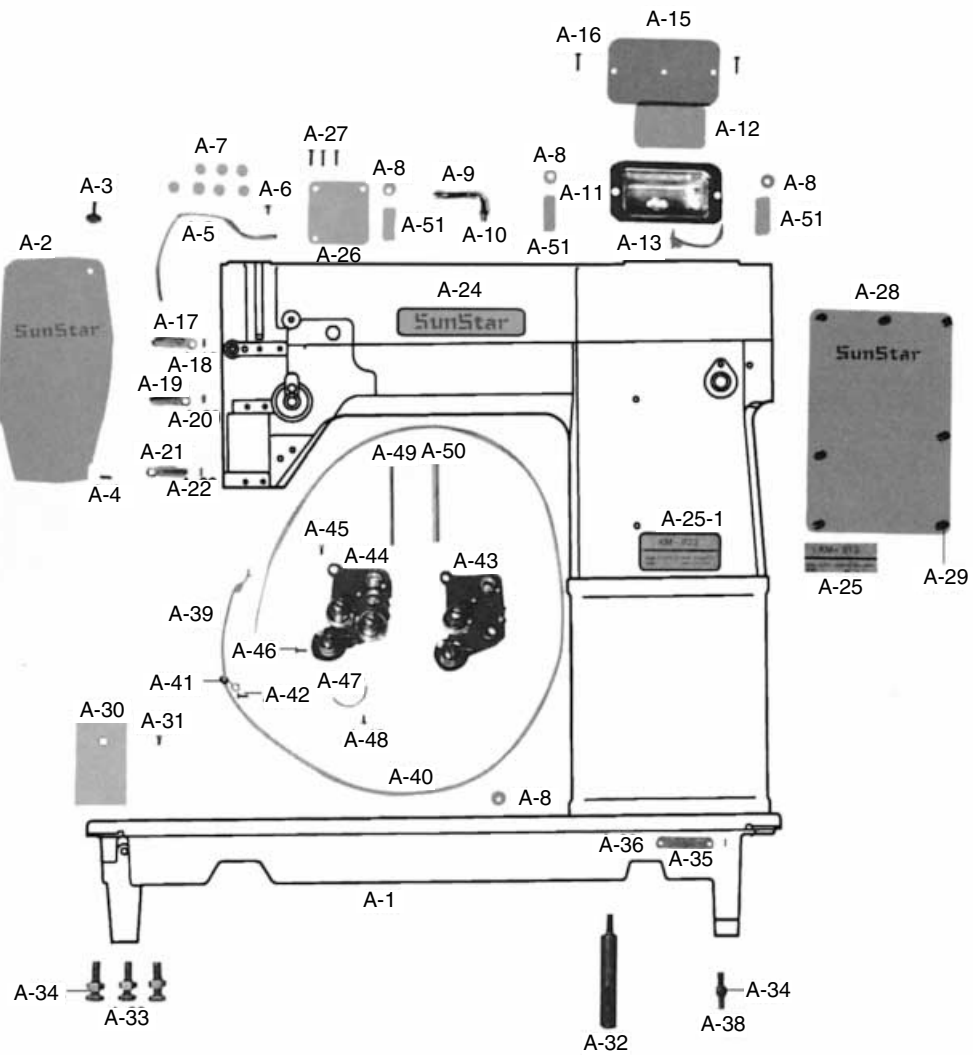



Ref. No.	Parts No.	Name of Parts	품 명	Q' ty		Assembly No.
				KM-813	KM-823	
A-1	01-001A-8130	Arm, Bed Base, Bed(Ass'y)	아암, 베드(조)	1Set	1Set	
A-2	01-005A-8130	Face Plate	면판	1	1	
A-3	SC-0322-7400	Screw(9/64" n=40)	홈볼이 둥근납작 작은나사(9/64" n=40)	1	1	
A-4	44-007P-1230	Lock Pin For A-2	롤핀 3×10	1	1	
A-5	01-006A-8130	Thread Take-Up Cover	실채기 커버	1	1	
A-6	SC-0502-2302	Screw(9/64" n=40)	홈볼이 둥근납작 작은나사(9/64" n=40)	1	1	
A-7	44-021R-7400	Rubber Cap	베드 기름 마개	10	10	
A-8	01-007R-8130	Oil Cap	고무마개 (Hole)	6	6	
A-9	01-010A-5607	Thread Retainer	윗실걸이	1	2	
A-10	SN-0121-7400	Nut(15/64" n=28)	육각너트(15/64" n=28)	1	2	
A-11	44-101A-8130	Oil Tank	오일탱크	1	1	
A-12	44-002M-8130	Oil Tank Felt	오일 탱크 felt	1	1	
A-13	44-0000-1230	Oil Wick	유심	1	1	
A-15	01-108A-8130	Oil Tank Cover	오일 탱크 커버	1	1	
A-16	SC-A301-4119	Screw(9/64" n=40)	홈볼이 접시 작은나사(9/64" n=40)	2	2	
A-17	01-021C-7400	Arm Thread Guide(U)	실걸이(상)	1	1	
A-18	SC-0519-2302	Screw(11/64" n=40)	홈볼이 둥근접시 작은나사(11/64" n=40)	1	1	
A-19	01-022C-7400	Arm Thread Guide(M)	실걸이(하)	1	1	
A-20	SC-0519-2302	Screw(11/64" n=40)	홈볼이 둥근접시 작은나사(11/64" n=40)	1	1	
A-21	01-022C-7400	Arm Thread Guide(L)	실걸이(하)	1	1	
A-22	SC-0519-2302	Screw(11/64" n=40)	홈볼이 둥근접시 작은나사(11/64" n=40)	1	1	
A-24	01-010M-2350	Brand Mark	상표 마크(압부)	1	1	
A-25	01-009M-8130	Model Mark	모델 마크	1		
A-25-1	01-009M-8230	Model Mark	모델 마크		1	
A-26	01-110A-8130	Upper Shaft Collar Cover	상축 카라 커버	1	1	
A-27	SC-A301-4119	Screw(9/64" n=40)	홈볼이 접시 작은나사(9/64" n=40)	3	3	
A-28	01-011A-8130	Rear Cover	뒷커버	1	1	
A-29	SC-0543-2302	Screw(11/64" n=40)	홈볼이 납작 작은나사(11/64" n=40)	7	7	
A-30	01-012A-8130	Slide Plate	미끄럼판	1	1	
A-31	SC-0501-2302	Screw(11/64" n=40)	홈볼이 둥근접시 작은나사(11/64" n=40)	1	1	
A-32	01-013A-8130	Bed Leg	베드 다리	1	1	
A-33	SC-0329-8130	Screw(M8×1.25)	육각 보울트(M8×1.25)	3	3	
A-34	01-014C-8130	Nut For A-33, A-38	베드 받침 너트(M8×P1.25 3중)	4	4	
A-35	01-035P-1370	Machine Number Plate	번호판	1	1	
A-36	01-035P-7400	Pin For A-35	번호판 핀	2	2	
A-38	SC-0348-8130	Screw (M8×1.25)	홈볼이 멈춤나사(M8×1.25)	1	1	
A-39	44-0000-1230	Oil Wick	유심	1	1	
A-40	44-012C-1230	Tube For A-39	환류 파이프	1	1	
A-41	44-026G-7400	Holder For A-39	felt잡이 스프링	1	1	
A-42	SC-0502-2302	Screw(9/64" n=40)	홈볼이 둥근납작 작은나사(9/64" n=40)	1	1	
A-43	01-004A-8170	Thread Tension Control Ass'y	실조절장치(조)	1Set		
A-44	01-018A-7400	Thread Tension Control Ass'y	실조절장치(조)		1Set	
A-45	SC-0543-2302	Screw(11/64" n=40)	홈볼이 납작 작은나사(11/64" n=40)	1	1	
A-46	SC-0158-3710	Screw(9/64" n=40)	홈볼이 납작 작은나사(9/64" n=40)	1	1	
A-47	01-019C-7400	Stopper For Thread Take-Up Spring	실조절 장치 스톱퍼	1	1	
A-48	SC-0502-2302	Screw(9/64" n=40)	홈볼이 둥근납작 작은나사(9/64" n=40)	1	1	
A-49	01-026C-7400	Tension Release Bar	실늦추기 축	1	1	
A-50	01-025C-7400	Pipe For A-49	동 파이프	1	1	
A-51	44-019M-7400	Oil Supply Felt	혹 몸체 전봇싱 felt(6-19)	3	3	

Upper Shaft & Needle Bar Mechanism

상축 및 바늘대 관계

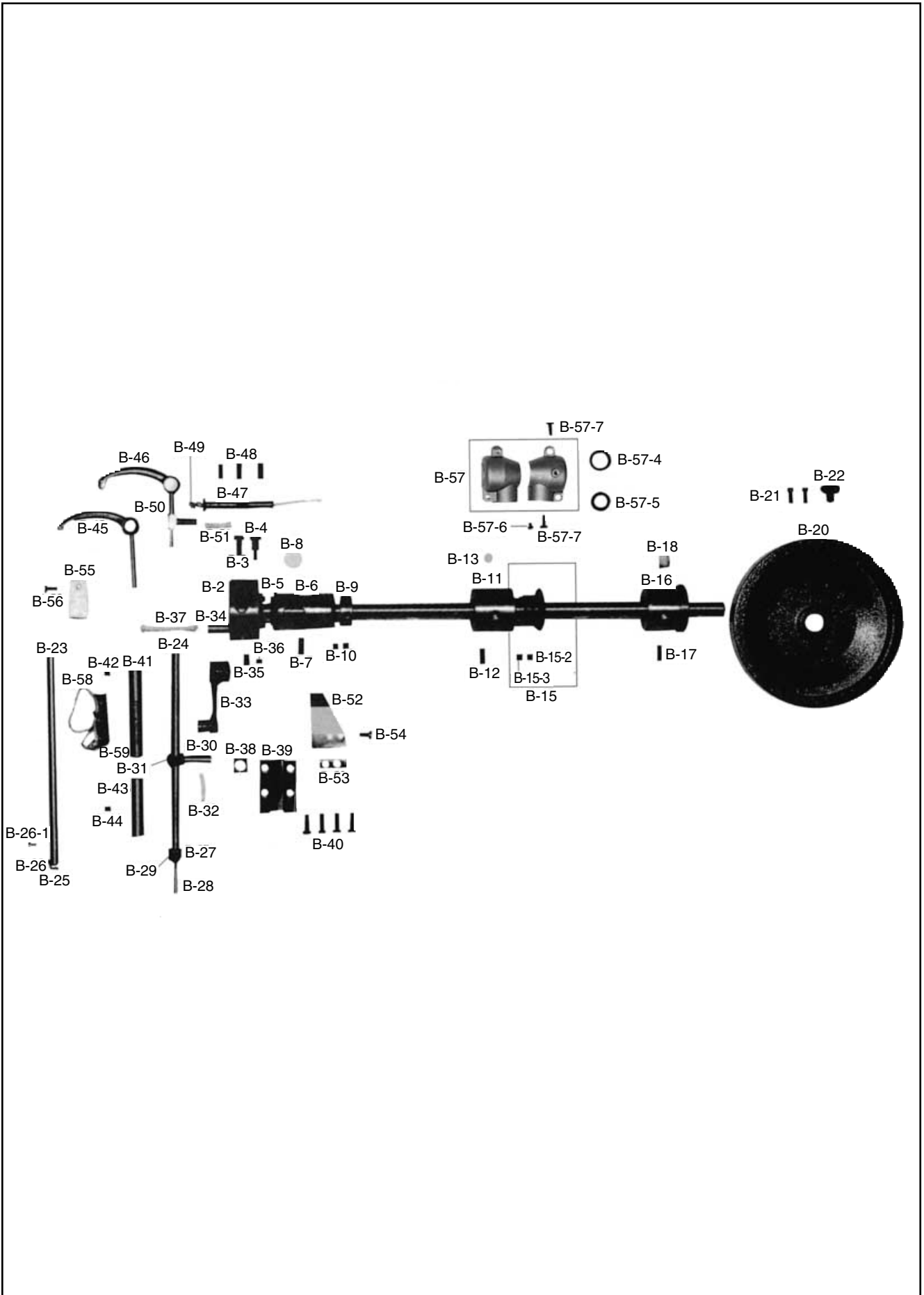



Ref. No.	Parts No.	Name of Parts	품 명	Q'ty		Assembly No.
				KM-813	KM-823	
B-1	02-101A-8130	Upper Shaft	상축	1	1	
B-2	02-002A-8150	Link Cam	링크 캠(HP)	1	1	
B-3	SC-0124-7400	Screw(9/32" n=28)	홈볼이 납작 작은나사(9/32" n=28)	1	1	
B-4	SC-0123-1230	Screw(9/32" n=28)	홈볼이 납작 작은나사(9/32" n=28)	1	1	
B-6	02-108A-8130	Upper Shaft Bushing(F)	상축 전봇싱	1	1	
B-7	SC-0514-7400	Screw(15/64" n=28)	홈볼이 멈춤나사(15/64" n=28)	1	1	
B-8	02-009M-7400	Felt For B-6	상축 앞봇싱 헬트	1	1	
B-9	02-121A-1230	Collar For B-1	상축 카라	1	1	
B-10	SC-A129-4515	Screw(1/4" n=40)	홈볼이 멈춤나사(1/4" n=40)	2	2	
B-11	02-104A-3400	Upper Shaft Bushing(M)	상축 중봇싱	1	1	
B-12	SC-0514-7400	Screw(15/64" n=28)	육각구멍볼이 멈춤나사(15/64" n=28)	1	1	
B-13	44-017M-3400	Felt For B-11	상축 중봇싱 급유 헬트	1	1	
B-15	02-211A-1230	Upper Shaft Gear Assembly	상축 기어	1	1	B-15 Upper Shaft Gear Assembly
B-15-2	SC-A129-4515	Screw(1/4" n=40)	홈볼이 멈춤나사(1/4" n=40)	1	1	
B-15-3	SC-A129-4515	Screw(1/4" n=40)	홈볼이 멈춤나사(1/4" n=40)	1	1	
B-16	02-105A-3400	Upper Shaft Bushing(R)	상축 후봇싱	1	1	
B-17	SC-0514-7400	Screw(15/64" n=28)	홈볼이 멈춤나사(15/64" n=28)	1	1	
B-18	44-020C-7400	Felt For B-16	후 몸체 전봇싱 헬트(6-19)	1	1	
B-20	02-006A-3400	Pulley	풀리	1	1	
B-21	SC-0150-2500	Screw(15/64" n=28)	홈볼이 납작 작은나사(15/64" n=28)	2	2	
B-22	SC-0188-1230	Screw(5/16" n=24)	홈볼이 바인딩 작은나사(5/16" n=24)	1	1	
B-23	04-101A-8170	Needle Bar	바늘대	1		
B-24	04-001A-7400	Needle Bar	바늘대		1	
B-25	04-002C-8170	Needle Bar Thread Guide	바늘대 실결이	1		
B-26	SC-0125-5607	Screw(3/32" n=56)	홈볼이 바인딩 작은나사(3/32" n=56)	1		
B-26-1	SC-A131-4522	Screw(1/8" n=44)	홈볼이 납작 작은나사(1/8" n=44)	1		
B-27	04-011A-8260	Needle Clamp	침지(1/16")		1	
B-28		Needle	바늘	1	2	
B-29	SC-0160-5607	Screw(9/64" n=40)	홈볼이 둥근납작 작은나사(9/64" n=40)		2	
B-30	04-102A-7400	Needle Bar Holder	바늘대 잡이	1	1	
B-31	SC-0158-3710	Screw(9/64" n=40)	홈볼이 납작 작은나사(9/64" n=40)	1	1	
B-32	06-033M-7400	Felt For B-30	절환기 헬트	1	1	
B-33	04-004A-7400	Needle Bar Crank	바늘대 크랭크	1	1	
B-34	02-104P-7400	Needle Bar Crank Shaft	링크캠 핀	1	1	
B-35	SC-0504-1230	Screw(1/4" n=40)	홈볼이 멈춤나사(1/4" n=40)	1	1	
B-36	SC-0129-7400	Screw(1/4" n=40)	홈볼이 멈춤나사(1/4" n=40)	1	1	
B-37	44-0000-1230	Oil Wick	유심	1	1	
B-38	04-105A-7400	Needle Bar Guide Slide Block	바늘대 안내블럭	1	1	
B-39	04-003A-8260	Needle Bar Crank Guide	바늘대 크랭크 안내	1	1	
B-40	SC-0497-1230	Screw(3/16" n=28)	홈볼이 납작 작은나사(3/16" n=28)	4	4	
B-41	04-107A-8260	Needle Bar Bushing(U)	바늘대 상봇싱	1	1	
B-42	SC-0114-1230	Screw(15/64" n=28)	홈볼이 멈춤나사(15/64" n=28)	1	1	
B-43	04-108A-8260	Needle Bar Bushing(L)	바늘대 하봇싱	1	1	
B-44	SC-0114-1230	Screw(15/64" n=28)	홈볼이 멈춤나사(15/64" n=28)	1	1	
B-45	02-104A-8270	Thread Take-Up Lever	실채기	1		
B-46	02-104A-8270	Thread Take-Up Lever	실채기		1	
B-47	08-101A-8130	Hinge Pin For Take-Up Lever	실채기 힌지핀	1	1	
B-48	SC-0514-7400	Screw(15/64" n=28)	홈볼이 멈춤나사(15/64" n=28)	2	2	
B-49	44-0000-1230	Oil Wick	유심	1	1	
B-50	02-103A-7400	Take-Up Lever Holder	실채기 잡이	1	1	
B-51	06-033M-7400	Felt	절환기 헬트	1	1	
B-52	44-017C-7400	Oil Cover	기름막이 판	1	1	
B-53	44-018C-8130	Oil Cover Holder	기름막이 누름판	1	1	
B-54	06-024S-7400	Screw(3/16" n=32)	홈볼이 냄비 작은나사(3/16" n=32)	1	1	
B-55	44-016M-7400	Felt For Thread Take-Up Lever	실채기 급유 헬트(6-14)	1	1	
B-56	SC-0158-3710	Screw(9/64" n=40)	홈볼이 냄비 작은나사(9/64" n=40)	1	1	
B-57	03-010A-3710	Upper Gear Case Assembly	상기어 케이스(조)	1	1	B-57 Upper Gear Case Assembly
B-57-4	03-013R-3710	Upper Shaft Retainer(F)	오일셀(B)	1	1	
B-57-5	03-014R-3710	Upper Shaft Retainer(R)	오일셀(C)	1	1	
B-57-6	SC-0205-3710	Screw(1/4" n=24)	홈볼이 납작 작은나사(1/4" n=24)	1	1	
B-57-7	SC-0109-2350	Screw(M6)	육각구멍볼이 보울트(M6)	2	2	
B-58	44-0000-1230	Oil Wick	유심	1	1	
B-59	04-002C-8260	Holder For B-58	바늘대 유심잡이	1	1	



Presser Foot & Knee Lifting Mechanism

누름대 및 무릎올림 관계

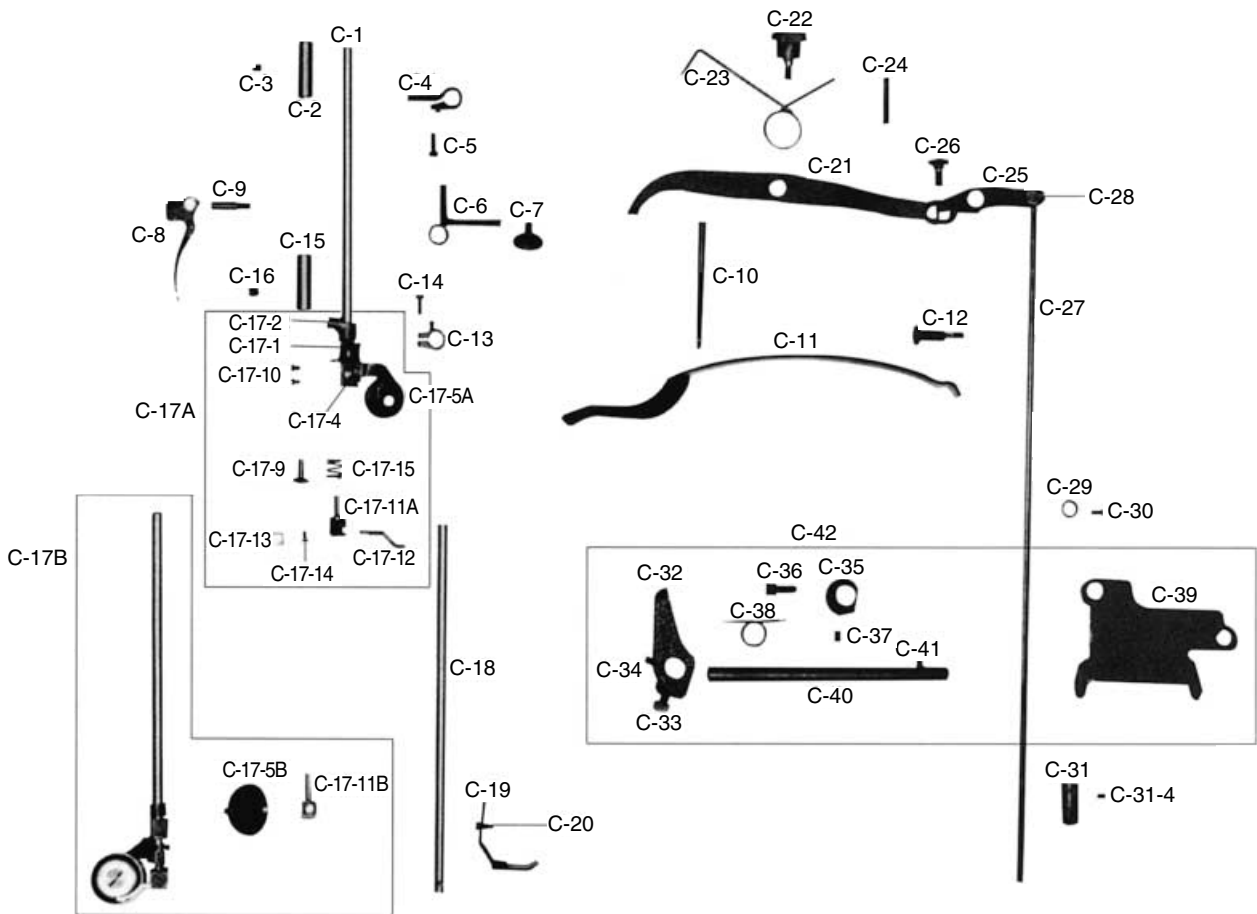



Ref. No.	Parts No.	Name of Parts	품명	Q'ty		Assembly No.
				KM-813	KM-823	
C-1	05-101A-8260	Roller Presser Bar	누름대	1	1	
C-2	05-102A-7400	Presser Bar Bushing(U)	누름대 상붓싱	1	1	
C-3	SC-0114-1230	Screw(15/64" n=28)	홈볼이 멈춤나사(15/64" n=28)	1	1	
C-4	05-103A-7400	Presser Bar Holder	누름대 잡이(K3300)	1	1	
C-5	SC-A174-4122	Screw(11/64" n=40)	홈볼이 납작 작은나사(11/64" n=40)	1	1	
C-6	05-104A-7400	Presser Bar Bracket	누름대 올리기 브라켓(K008)	1	1	
C-7	05-005S-7400	Stud For C-6	누름대 올리기 단나사	1	1	
C-8	05-006A-7400	Presser Foot Lifter	누름대 올리기	1	1	
C-9	05-009P-3800	Hinge Pin For C-8	누름대 올리기 힌지핀	1	1	
C-10	05-015S-7400	Presser Adjusting Screw	압력 조절 나사	1	1	
C-11	05-116G-8130	Presser Bar Plate Spring	누름대판 스프링	1	1	
C-12	05-017S-7400	Hinge Screw For C-11	누름대판 스프링 단나사	1	1	
C-13	05-008A-7400	Hook For P.B. Plate Spring	누름대판 스프링 걸이(K001)	1	1	
C-14	SC-0158-3710	Screw(9/64" n=40)	홈볼이 납작 작은나사(9/64" n=40)	1	1	
C-15	05-009A-7400	Presser Bar Bushing(L)	누름대 하붓싱	1	1	
C-16	SC-0114-1230	Screw(15/64" n=28)	홈볼이 멈춤나사(15/64" n=28)	1	1	
C-17-1	81-104A-8260	Roller Presser Bracket	로올러 노루발 브라켓	1	1	C-17A Roller Presser Foot(L) Assembly
C-17-2	81-003S-8260	Stud For C-17-1	브라켓 힌지나사	1	1	
C-17-4	SC-0199-2700	Screw(11/64" n=40)	홈볼이 바인딩 작은나사(11/64" n=40)	1	1	C-17B Roller Presser Foot(S) Assembly (*)
C-17-5A	05-017A-8150	Roller Presser Foot(L)	로올러 노루발	1	1	
C-17-5B	81-011A-8260	Roller Presser Foot(S)	노루발(로올러) φ26	*	*	
C-17-9	04-005P-8260	Stopper Pin For C-17-1	브라켓 스토퍼 핀	1		
C-17-10	SC-0160-5607	Screw(9/64" n=40)	홈볼이 둥근납작 작은나사(9/64" n=40)	2	2	
C-17-11A	81-017A-8260	Needle Guide Holder(S)	로올러 노루발 바늘안내 홀더(소)		1	
C-17-11B	81-007A-8260	Needle Guide Holder(L)	로올러 노루발 바늘안내 홀더(대)		*	
C-17-12	81-016A-8260	Needle Guide(1/16")	로올러 노루발 바늘안내(1/16")		1	
C-17-13	81-005W-8260	Washer For C-17-12	로올러 노루발 홀더 와셔		1	
C-17-14	SC-0130-1230	Screw(1/8" n=44)	홈볼이 납작 작은나사(1/8" n=44)		1	
C-17-15	04-004G-8260	Spring For C-17-1	브라켓 스프링	1	1	
C-18	05-001A-7400	Flat Presser Bar	누름대	*	*	
C-19	05-001A-8170	Flat Presser Foot Assembly	노루발	1		
C-20	SC-0315-2302	Screw(9/64" n=40)	홈볼이 납작 작은나사(9/64" n=40)	1		
C-21	05-011A-7400	Knee Lifting Lever	무릎올림 레버	1	1	
C-22	05-013S-7400	Stud For C-21	무릎올림 레버 힌지나사	1	1	
C-23	05-014G-7400	Return Spring For C-21	무릎올림 레버 스프링	1	1	
C-24	05-012S-7400	Stopper for C-23	무릎올림 레버 스프링 걸이 나사	1	1	
C-25	43-101A-8130	Connecting Link For C-21	무릎올림 레버 연결 링크	1	1	
C-26	05-019S-7400	Stud For C-25	연결 링크 단나사	1	1	
C-27	43-002A-8130	Knee Lifting Connecting Rod	무릎올림 연결봉	1	1	
C-28	05-020P-2302	Pin For C-27	분할핀	2	2	
C-29	43-003A-8130	Collar For C-27	무릎올림 연결봉 카라	1	1	
C-30	SC-0128-7400	Screw(11/64" n=40)	홈볼이 납비 작은나사(11/64" n=40)	1	1	
C-31	43-015A-5607	Knee Lifting Roller Bracket Assembly	무릎 올림봉 로올러(조)	1	1	
C-31-4	SC-0542-1230	Screw(11/64" n=40)	홈볼이 멈춤나사(11/64" n=40)	1	1	
C-32	43-026A-7500	Knee Lifter Lock Lever	무릎올림 고정레버	1	1	C-42 Knee Lifting Assembly
C-33	43-026S-8130	Screw For C-32	무릎올림 레버 고정나사	1	1	
C-34	43-027S-8130	Screw For C-32	무릎올림 레버 고정나사(소)	1	1	
C-35	43-027A-8130	Lever Shaft Stopper Collar	레버축 스토퍼 카라	1	1	
C-36	SC-0107-1600	Screw(M6×1.0)	육각 보울트(M6×1.0)	1	1	
C-37	43-027S-8130	Screw For C-36	무릎올림 레버 고정나사(소)	1	1	
C-38	43-027G-8130	Lever Shaft Return Spring	레버축 리턴 스프링	1	1	
C-39	43-028A-8130	Lever Shaft Bracket	레버축 브라켓	1	1	
C-40	43-029A-8130	Lever Shaft	무릎올림 레버축	1	1	
C-41	43-030P-8130	Guide Pin For C-40	안내핀	1	1	
C-42	43-016A-8130	Knee Lifting Assembly	무릎올림(조)	1	1	

❖ The "*" Mark is Option Parts

Feed Mechanism
피이드 관계

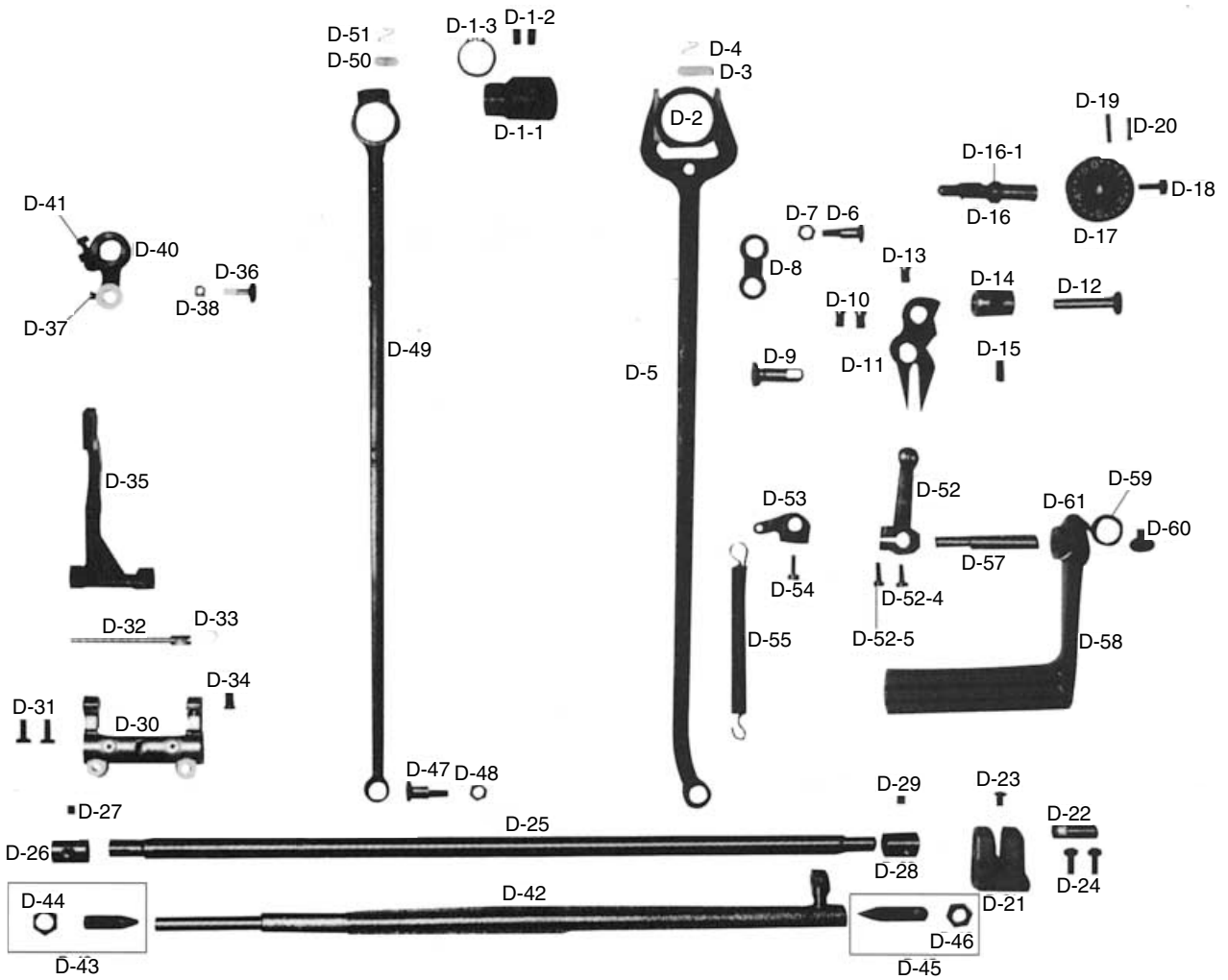



Ref. No.	Parts No.	Name of Parts	품 명	Q' ty		Assembly No.
				KM-813	KM-823	
D-1-1	06-001A-8130	Feed Cam	피드캠 (HP)	1	1	
D-1-2	SC-0114-1230	Screw(15/64" n=28)	홈볼이 멈춤나사(15/64" n=28)	2	2	
D-1-3	06-007C-1600	C-Ring For D-1-1	크랭크 로트 스톱퍼링(20D)	1	1	
D-2	06-102A-3400	Connection Ring For Y-Rod	와이로드 연결링	1	1	
D-3	44-018M-3400	Felt For D-2	와이로드 연결링 급유 헬트	1	1	
D-4	44-015C-3400	Oil Felt Holder For D-2	상하운동 캠 로트 유심잡이	1	1	
D-5	06-002A-8130	Y-Rod	와이로드(HP)	1	1	
D-6	06-032A-1230	Stud For D-5	피이드 조절기 연결 단나사	1	1	
D-7	SN-0107-1230	Nut(9/32" n=28)	육각너트(9/32" n=28)	1	1	
D-8	06-131A-1230	Feed Link	피이드 링크	1	1	
D-9	06-003A-8130	Feed Link Connecting Shaft	피이드 링크 연결축	1	1	
D-10	SC-0122-1230	Screw(15/64" n=28)	홈볼이 납작 작은나사(15/64" n=28)	2	2	
D-11	06-104A-8130	Feed Regulator	피이드 조절기 (HP)	1	1	
D-12	06-109A-3400	Feed Regulator Shaft	피이드 조절축	1	1	
D-13	SC-0122-1230	Screw(15/64" n=28)	홈볼이 납작 작은나사(15/64" n=28)	1	1	
D-14	06-110A-3400	Feed Regulator Bushing	피이드 조절축 붓싱	1	1	
D-15	SC-0507-1230	Screw(15/64" n=28)	홈볼이 멈춤나사(15/64" n=28)	1	1	
D-16	06-005A-8130	Feed Regulator Dial Shaft	피이드 조절 다이알 축	1	1	
D-16-1	06-010R-1230	O-Ring For D-16	다이알 축 오링	1	1	
D-17	06-012C-8130	Length Control Dial Shaft	다이알 판(조)	1	1	
D-18	SC-0193-1230	Screw(3/16" n=28)	홈볼이 납작 작은나사(3/16" n=28)	1	1	
D-19	06-012P-7400	Pin For D-17	다이알 핀	1	1	
D-20	06-027G-7400	Spring For D-17	다이알 스프링	1	1	
D-21	06-107A-8130	Feed Rock Shaft Crank	수평 밀대 크랭크(후)	1	1	
D-22	06-006P-8130	Connection Pin For D-21	수평 밀대 크랭크(후) 연결핀	1	1	
D-23	SC-0543-2302	Screw(11/64" n=40)	홈볼이 납작 작은나사(11/64" n=40)	1	1	
D-24	SC-0497-1230	Screw(3/16" n=28)	홈볼이 납작 작은나사(3/16" n=28)	2	2	
D-25	06-123A-1230	Feed Rock Shaft	밀대	1	1	
D-26	06-008A-8130	Feed Rock Shaft Bushing(F)	수평밀대 전붓싱	1	1	
D-27	SC-0114-1230	Screw(15/64" n=28)	홈볼이 멈춤나사(15/64" n=28)	1	1	
D-28	06-009A-8130	Feed Rock Shaft Bushing(R)	수평밀대 후붓싱	1	1	
D-29	SC-0114-1230	Screw(15/64" n=28)	홈볼이 멈춤나사(15/64" n=28)	1	1	
D-30	06-008A-1230	Feed Bar Crank	뜸니받침 크랭크	1	1	
D-31	SC-0307-1230	Screw(3/16" n=32)	홈볼이 납작 작은나사(3/16" n=32)	2	2	
D-32	06-109A-1230	Feed Bar Shaft	뜸니 받침축	1	1	
D-33	06-002W-2350	Washer For D-32	뜸니 받침축 와셔	1	1	
D-34	06-020S-1230	Screw(15/64" n=28)	홈볼이 납작 작은나사(15/64" n=28)	1	1	
D-35	06-110A-3400	Feed Bar	뜸니 받침	1	1	
D-36	06-026A-3400	Feed Bar Block Shaft	뜸니 받침 블럭축	1	1	
D-37	SC-0128-7400	Screw(11/64" n=40)	홈볼이 납비 작은나사(11/64" n=40)	1	1	
D-38	06-127A-3400	Feed Bar Block	뜸니 받침 블럭	1	1	
D-40	06-129A-3400	Feed Lifting Shaft Crank(F)	들대 크랭크(전)	1	1	
D-41	SC-0497-1230	Screw(3/16" n=28)	홈볼이 납작 작은나사(3/16" n=28)	1	1	
D-42	06-111A-8130	Feed Lifting Shaft	들대	1	1	
D-43	SC-0360-3400	Screw(3/8" n=28)	홈볼이 멈춤나사(3/8" n=28)	1	1	
D-44	06-031S-3400	Nut For D-43	들대 지지나사 너트	1	1	
D-45	SC-0358-8130	Screw(3/8" n=28)	홈볼이 멈춤나사(3/8" n=28)	1	1	
D-46	06-031S-3400	Nut For D-45	들대 지지나사 너트	1	1	
D-47	06-032A-1230	Stud For Crank Rod	피이드 조절기 연결 단나사	1	1	
D-48	SN-0107-1230	Nut(9/32" n=28)	육각너트(9/32" n=28)	1	1	
D-49	06-113A-8130	Crank Rod	크랭크 로트(HP)	1	1	
D-50	44-023M-3400	Felt For D-49	노루발 상하운동 캠 로트 급유 헬트	1	1	
D-51	44-015C-3400	Oil Felt Holder For D-49	상하운동 캠 로트 유심잡이	1	1	
D-52	06-060A-3400	Feed Regulator Arm Assembly	역진레버 크랭크(조)	1	1	D-52
D-52-4	SC-A174-4122	Screw(11/64" n=40)	홈볼이 납작 작은나사(11/64" n=40)	1	1	Feed Regulator Arm Assembly
D-52-5	SC-0184-1600	Screw(3/16" n=28)	홈볼이 납비 작은나사(3/16" n=28)	1	1	
D-53	06-135C-2350	Upper Spring Holder	역진 레버 스프링 결이(상)	1	1	
D-54	SC-0307-1230	Screw(3/16" n=32)	홈볼이 납작 작은나사(3/16" n=32)	1	1	
D-55	06-003G-8130	Reverse Lever Spring	역진 레버 인장 스프링	1	1	
D-57	06-114A-8130	Reverse Lever Shaft	역진 레버 축	1	1	
D-58	06-037A-8130	Reverse Lever	역진 레버 (HP)	1	1	
D-59	06-053W-1230	Washer For D-58	레버 와셔	1	1	
D-60	SC-0185-1230	Screw(3/16" n=32)	홈볼이 바인딩 작은나사(3/16" n=32)	1	1	
D-61	SC-0186-1230	Screw(3/16" n=32)	홈볼이 납비 작은나사(3/16" n=32)	1	1	

Upright Shaft & Lower Shaft Mechanism

입축 및 하축 관계

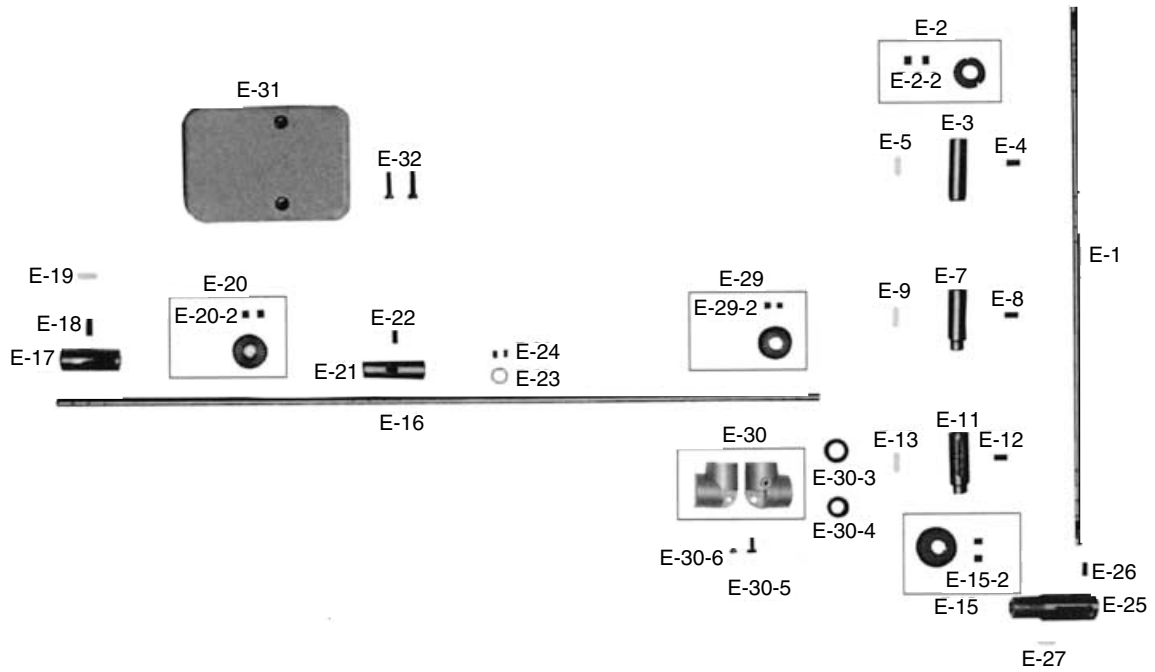



Ref. No.	Parts No.	Name of Parts	품 명	Q' ty		Assembly No.
				KM-813	KM-823	
E-1	03-101A-8130	Upright Shaft	세운축	1	1	
E-2	02-212A-1230	Upright Shaft Upper Gear(U) Assembly	입축 상기어	1	1	E-2. Upright Shaft Gear(U) Assembly
E-2-2	SC-A129-4515	Screw(1/4" n = 40)	홈볼이 멈춤나사(1/4" n = 40)	2	2	
E-3	03-102A-3400	Upright Shaft Bushing(U)	세운축 상붓싱	1	1	
E-4	SC-0507-1230	Screw(15/64" n = 28)	홈볼이 멈춤나사(15/64" n = 28)	1	1	
E-5	03-007M-3710	Felt For E-3	입축 상붓싱 헬트	1	1	
E-7	03-102A-8130	Upright Shaft Bushing(M)	세운축 중붓싱	1	1	
E-8	SC-0507-1230	Screw(15/64" n = 28)	홈볼이 멈춤나사(15/64" n = 28)	1	1	
E-9	03-007M-3710	Felt For E-7	입축 상붓싱 헬트	1	1	
E-11	03-103A-8130	Upright Shaft Bushing(L)	세운축 하붓싱	1	1	
E-12	SC-0507-1230	Screw(15/64" n = 28)	홈볼이 멈춤나사(15/64" n = 28)	1	1	
E-13	03-007M-3710	Felt For E-11	입축 상붓싱 헬트	1	1	
E-15	02-213A-1230	Upright Shaft Lower Gear(L) Assembly	입축 하기어	1	1	E-15. Upright Shaft Gear(L) Assembly
E-15-2	SC-A129-4515	Screw(1/4" n = 40)	홈볼이 멈춤나사(1/4" n = 40)	2	2	
E-16	07-101A-8130	Lower Shaft	하축	1	1	
E-17	07-002A-1600	Lower Shaft Bushing(F)	입축 하붓싱	1	1	
E-18	SC-0507-1230	Screw(15/64" n = 28)	홈볼이 멈춤나사(15/64" n = 28)	1	1	
E-19	03-007M-3710	Felt For E-17	입축 상붓싱 헬트	1	1	
E-20	07-004A-8150	Lower Shaft Gear (F) Assembly	하축 기어(조)	1	2	E-20 Assembly
E-20-2	SC-A129-4515	Screw(1/4" n = 40)	홈볼이 멈춤나사(1/4" n = 40)	2	4	
E-21	08-103A-8130	Lower Shaft Bushing(M)	하축 중붓싱	1	1	
E-22	SC-0507-1230	Screw(15/64" n = 28)	홈볼이 멈춤나사(15/64" n = 28)	1	1	
E-23	44-119A-1230	Collar For E-16	오일 펌프 카라	1	1	
E-24	SC-0542-1230	Screw(11/64" n = 40)	홈볼이 멈춤나사(11/64" n = 40)	2	2	
E-25	08-104A-8130	Lower Shaft Bushing(R)	하축 후붓싱	1	1	
E-26	SC-0507-1230	Screw(15/64" n = 28)	홈볼이 멈춤나사(15/64" n = 28)	1	1	
E-27	03-007M-3710	Felt For E-25	입축 상붓싱 헬트	1	1	
E-29	02-214A-1230	Lower Shaft Gear(R) Assembly	하축 뒷기어	1	1	E-29. Lower Shaft Gear(R) Assembly
E-29-2	SC-A129-4515	Screw(1/4" n = 40)	홈볼이 멈춤나사(1/4" n = 40)	2	2	
E-30	03-016A-3710	Lower Gear Case Assembly	하기어 케이스(조)	1	1	E-30 Lower Gear Case Assembly
E-30-3	03-015R-3710	Oil Seal(D)	오일셀(D)	1	1	
E-30-4	03-017R-3710	Oil Seal(E)	오일셀(E)	1	1	
E-30-5	SC-A174-4122	Screw(M6)	육각구멍볼이 보울트(M6)	1	1	
E-30-6	SC-0205-3710	Screw(1/4" n = 24)	홈볼이 납작 작은나사(1/4" n = 24)	1	1	
E-31	44-003A-8130	Lower Shaft Gear Case	하축 기어 케이스	1	1	
E-32	SC-0184-1600	Screw(3/16" n = 28)	홈볼이 냄비 작은나사(3/16" n = 28)	2	2	

Post Mechanism

포스트 관계

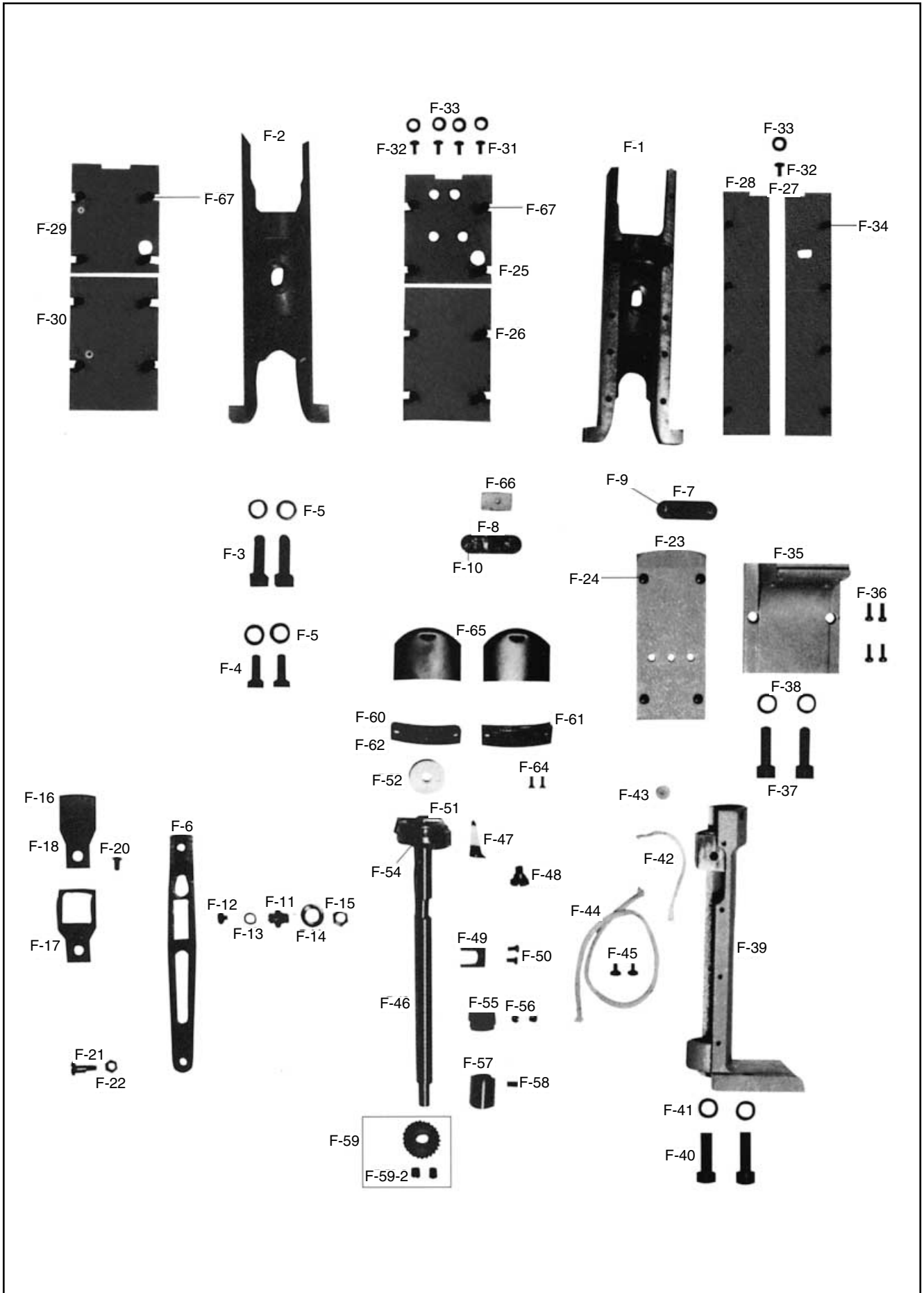



Ref. No.	Parts No.	Name of Parts	품 명	Q'ty		Assembly No.
				KM-813	KM-823	
F-1	09-105A-8130	Post	포스트	1		
F-2	09-101A-8230	Post	포스트		1	
F-3	SC-0344-8260	Screw(5/16" n=24)	홈볼이 등근납작 작은나사(5/16" n=24)	2	2	
F-4	SC-0253-7400	Screw(1/4" n=24)	홈볼이 냄비 작은나사(1/4" n=24)		2	
F-5	09-025W-8270	Washer For F-3, F-4	새들 쥘나사 와셔	2	4	
F-6	09-002A-8130	Feed Dog Lever	톱니 레버	1	1	
F-7	09-005C-8270	Guide Plate For F-6	톱니 레버 보강판	1		
F-8	09-005C-8270	Guide Plate For F-6	톱니 레버 보강판		1	
F-9	SC-0501-4120	Screw(11/64" n=40)	홈볼이 등근접시 작은나사(11/64" n=40)	2		
F-10	SC-0175-4522	Screw(11/64" n=40)	홈볼이 납작 작은나사(11/64" n=40)		2	
F-11	09-006S-8270	Slide Block Shaft	슬라이드 블럭 나사	1	1	
F-12	09-008S-8270	Screw For F-11	슬라이드 블럭 마감나사	1	1	
F-13	09-107A-8270	Slide Block	톱니 레버 슬라이드 블럭	1	1	
F-14	09-009W-8270	Washer For F-11	슬라이드 블럭 와셔	1	1	
F-15	SN-0116-4000	Nut(1/4" n=40)	육각너트(1/4" n=40)	1	1	
F-16	06-001A-8160	Feed Dog(Roller Presser Type)	톱니(로올러 노루발용)	1		
F-17	06-001A-8260	Feed Dog(Roller Presser Type)	톱니(로올러 노루발용)		1	
F-18	06-011A-8160	Feed Dog(Flat Presser Type)	톱니(평 노루발용)	*		
F-20	SC-0543-4525	Screw(11/64" n=40)	홈볼이 등근접시 작은나사(11/64" n=40)	1	1	
F-21	06-008S-8270	Stud For Feed Bar(D-35)	톱니 받침 나사	1	1	
F-22	SN-0115-4000	Nut(3/16" n=32)	육각너트(3/16" n=32)	1	1	
F-23	09-001A-8170	Post Left Cover	포스트 카바(좌)	1		
F-24	SC-0501-4120	Screw(11/64" n=40)	홈볼이 등근납작 작은나사(11/64" n=40)	4		
F-25	09-021C-8230	Post Front Cover(U)	포스트 카바(전) 상		1	
F-26	09-022C-8230	Post Front Cover(L)	포스트 카바(전) 하		1	
F-27	09-123C-8170	Post Right Cover(F)	포스트 카바(전) 우	1		
F-28	09-124C-8170	Post Left Cover(R)	포스트 카바(후) 좌	1		
F-29	09-023C-8230	Post Rear Cover(U)	포스트 카바(후) 상		1	
F-30	09-024C-8230	Post Rear Cover(L)	포스트 카바(후) 하		1	
F-31	SC-0538-4125	Screw(3/16" n=32)	홈볼이 등근납작 작은나사(3/16" n=32)		1	
F-31	SC-0537-4125	Screw(3/16" n=32)	홈볼이 등근납작 작은나사(3/16" n=32)			
F-32	SC-0537-4125	Screw(3/16" n=32)	홈볼이 등근납작 작은나사(3/16" n=32)	1	3	
F-33	01-023C-3710	Washer For F-31, F-32	와셔5	1	4	
F-34	SC-A301-4119	Screw(9/64" n=40)	홈볼이 접시 작은나사(9/64" n=40)	8		
F-35	09-002A-8170	Post Support	포스트 받침	1		
F-36	SC-0179-4125	Screw(11/64" n=40)	홈볼이 등근납작 작은나사(11/64" n=40)	4		
F-37	SC-0326-4122	Screw(5/16" n=24)	홈볼이 납작 작은나사(5/16" n=24)	2		
F-38	09-025W-8270	Washer For F-37	새들 쥘나사 와셔	2		
F-39	09-004A-8130	Saddle	새들	1	2	
F-40	SC-0326-4122	Screw(5/16" n=24)	홈볼이 납작 작은나사(5/16" n=24)	2	4	
F-41	09-025W-8270	Washer For F-40	새들 쥘나사 와셔	2	4	
F-42	44-0000-1230	Oil Wick	유심	1	1	
F-43	44-020C-7400	Felt For F-39	흑 몸체 후붓싱 헬트	1	2	
F-44	44-0000-1230	Oil Wick	유심	1	1	
F-45	SC-0365-4118	Screw(9/64" n=40)	홈볼이 냄비 작은나사(9/64" n=40)	2	4	
F-46	09-040A-8150	Hook Shaft	가마축	1	2	
F-47	09-014A-8270	Opener	오프너	1	2	
F-48	09-015S-8270	Stud For F-47	오프너 단나사	1	2	
F-49	09-016A-8270	Fork For F-47	오프너 블럭	1	2	
F-50	SC-0502-4125	Screw(9/64" n=40)	홈볼이 등근납작 작은나사(9/64" n=40)	2	4	
F-51	09-036A-8570	Rotary Hook Assembly	가마HSH-31(6)	1Set	2Set	
F-52	09-130A-7400	Bobbin	보빈	1	2	
F-54	SC-0147-4114	Screw(9/64" n=40)	접시머리 보울트(9/64" n=40)	1	2	
F-55	09-001A-8130	Collar For F-46	흑 축 카라	1	2	
F-56	SC-0129-4515	Screw(1/4" n=40)	홈볼이 멈춤나사(1/4" n=40)	1	2	
F-57	09-006A-8130	Bushing For F-46	들대 붓싱 (후) 11.11×16.8×20	2	4	
F-58	SC-0499-4515	Screw(11/64" n=40)	홈볼이 멈춤나사(11/64" n=40)	1	2	
F-59	09-053A-8150	Hook Shaft Gear Assembly	흑 기어(조) (나사포함)	1	2	F-59, Hook Shaft Gear Assembly
F-59-2	SC-A129-4515	Screw(1/4" n=40)	홈볼이 멈춤나사(1/4" n=40)	2	4	
F-60	01-005A-8160	Needle Plate(Roller Presser Type)	침판(로올러 노루발용)	1		
F-61	01-015A-8260	Needle Plate	침판(1/16")	1	1	
F-62	01-015A-8160	Needle Plate(Flat Presser Type)	침판(평 노루발용)		1	
F-64	SC-0310-4119	Screw(9/64" n=40)	홈볼이 접시 작은나사(9/64" n=40)	2	2	
F-65	09-202C-8270	Hook Cover	가마축 슬라이드	1	2	
F-66	06-053M-7400	Felt For F-6	포크 헬트	1	1	
F-67	SC-0502-4125	Screw(9/64" n=40)	홈볼이 등근납작 작은나사(9/64" n=40)		16	

❖ The "*" Mark is Option Parts



Accessories
액세서리 관계

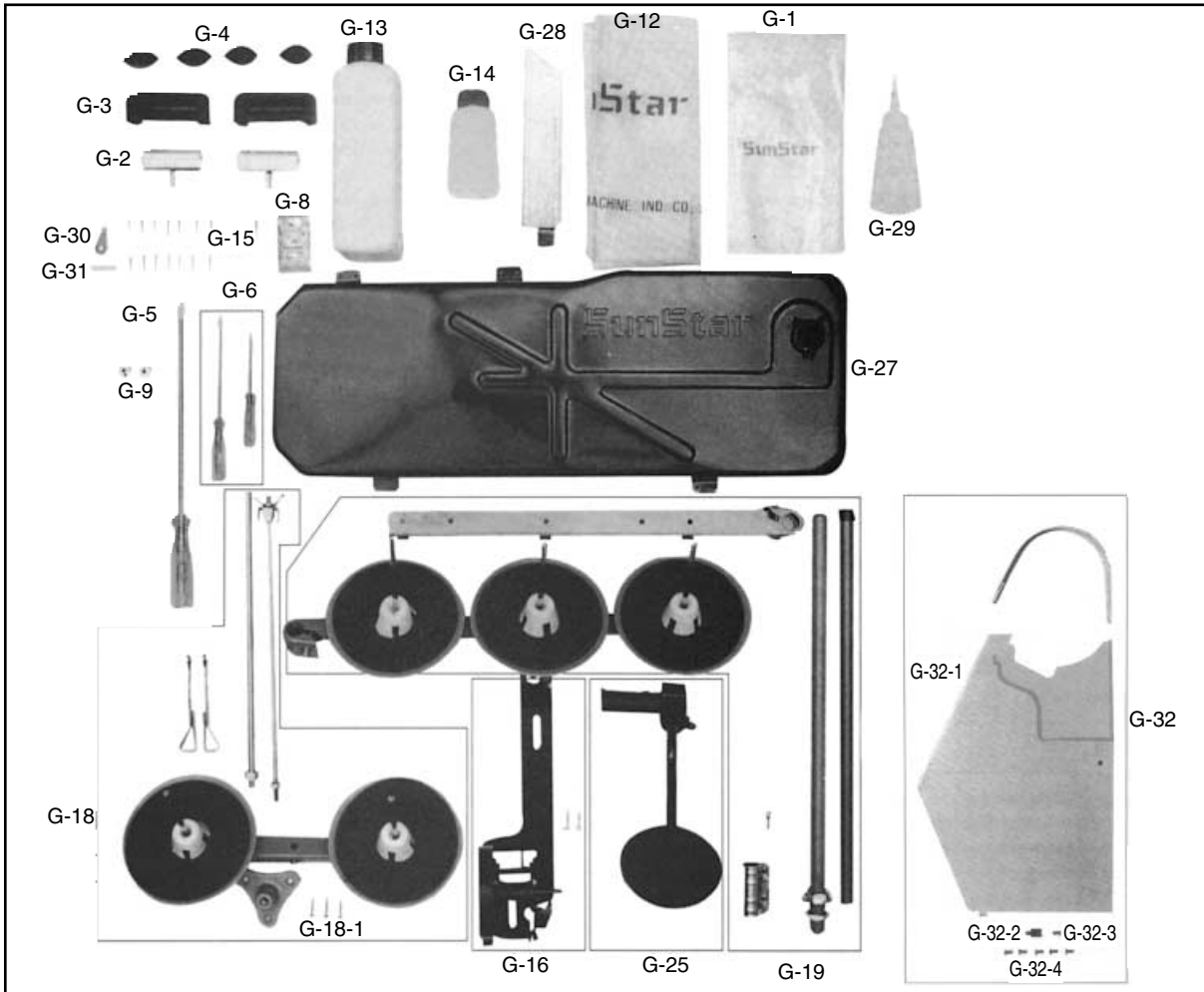

Ref. No.	Parts No.	Name of Parts	품 명	Q' ty		Assembly No.
				KM-813	KM-823	
G-1	91-001C-1230	Accessory Bag	액세서리 박스	1	1	
G-2	01-043C-1230	Hinge Assembly	힌지	2	2	
G-3	91-106R-7400	Rubber Cushion	흰지고무(대) (White)	2	2	
G-4	91-103R-7400	Head Cushion	흰지고무(소)	4	4	
G-5	91-002C-1230	Screw Driver(L)	드라이버(대)	1	1	
G-6	91-003C-1230	Driver(M, S)	드라이버(중, 소)	1	1	
G-8		Needle	바늘	1Set	1Set	
G-9	09-130A-7400	Bobbin	보빈	2	2	
G-12	91-001C-8270	Machine Head Cover	미싱커버(소)	1	1	
G-13	91-108C-1230	Oil Tank	오일 캔	1	1	
G-14	91-011C-1230	Oiler	유차	1	1	
G-15		Nail	못	14	14	
G-16	41-101A-1230	Bobbin Winder Assembly	실감기(조)	1Set	1Set	
G-18	91-007A-2302	Thread Stand Assembly	실폐꽃이(조)	1Set		
G-18-1	91-003C-2302	Screw For G-18	목나사	3		
G-19	91-008A-7400	Thread Stand Assembly	실폐꽃이(조)(3분 사립봉)		1Set	
G-25	43-100A-7500	Knee Lifter Assembly	무릎 올림(조)	1	1	
G-27	44-002A-8130	Oil Pan Assembly	오일팬(조)	1	1	
G-28	90-003A-8670	Head Rest	두부지지봉	1	1	
G-29	91-002C-7400	Oil Receiver	유차병	1	1	
G-30	91-007C-7400	Needle Thread Inserting Guide	실끼기	1	1	
G-31	01-024M-7400	Felt For Upper Thread Supply	윗실 급유 헬트	1	1	
G-32	60-101A-8130	Belt Cover Ass'y	벨트커버(조)	1Set	1Set	
G-32-1	60-001A-8130	Belt Cover	벨트커버	1	1	
G-32-2	60-006P-8670	Support Pin For Belt Cover	벨트커버 지지핀	1	1	
G-32-3	01-016R-2700	Stopper For Belt Cover	스토퍼	1	1	
G-32-4	SC-0543-2302	Screw For Belt Cover	나사	5	5	



Gauge Parts
 게이지 관계

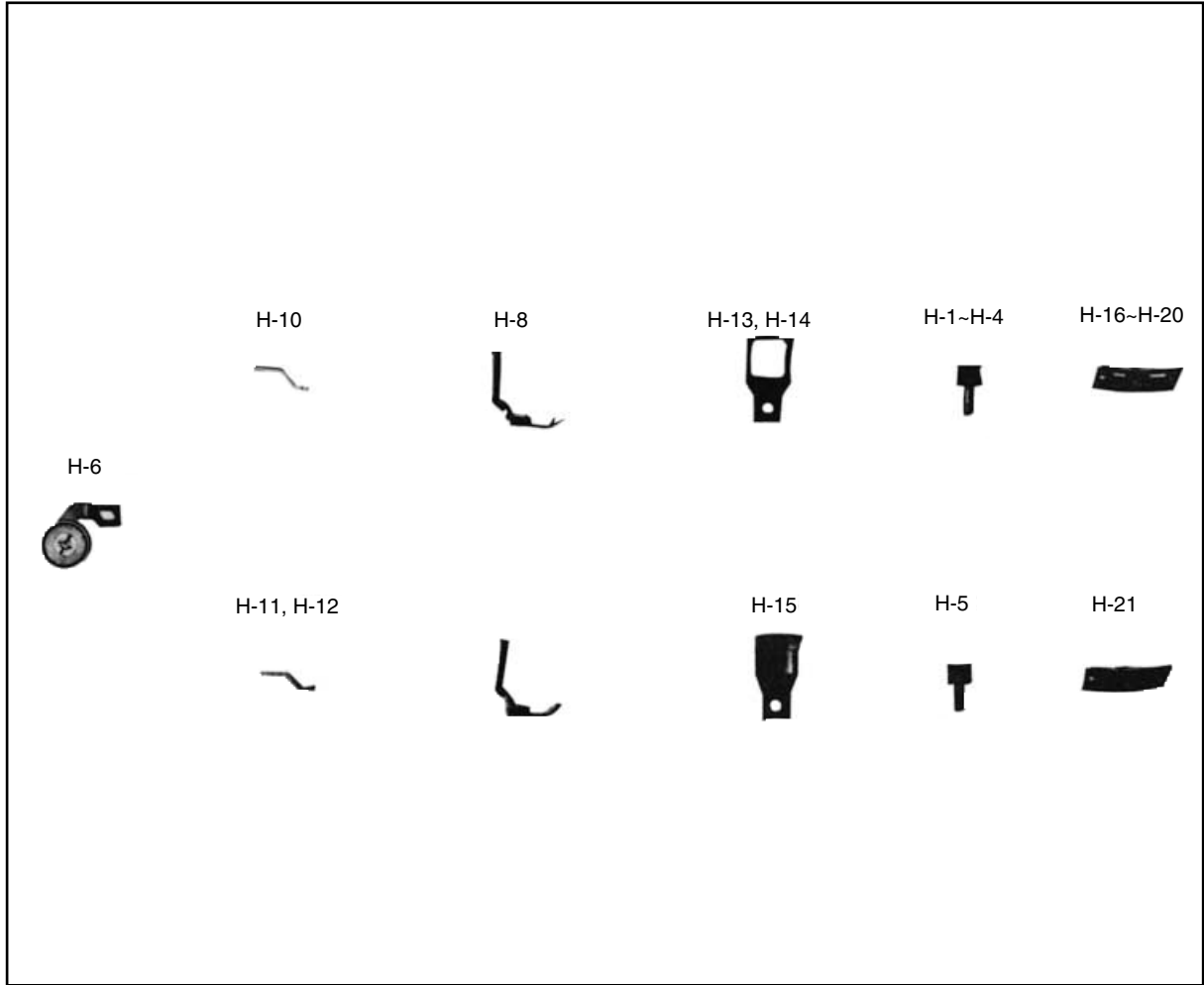

Ref. No.	Parts No.	Name of Parts	품명	Gauge Size						
				Inch	3/64	1/16	3/32	1/8	1/4	
				mm	1	1.2	1.6	2.4	3.2	6.4
H-1	04-021A-8260	Needle Clamp(3/64)	침지(3/64)		1	1				
H-2	04-011A-8260	Needle Clamp(1/16)	침지(1/16)				1			
H-3	04-001A-8260	Needle Clamp(3/32)	침지(3/32)					1		
H-4	04-031A-8260	Needle Clamp(1/8)	침지(1/8)						1	
H-5	04-041A-8260	Needle Clamp(1/4)	침지(1/4)							1
H-6	81-017A-8150	Roller Presser(S)	노루발(로올러)(소)		1	1	1	1	1	
H-8	05-001A-8160	Flat Presser Foot(KM-813)	노루발							
H-10	81-016A-8260	Needle Guide(1/16)	로올러 노루발 바늘안내(1/16)		1	1	1			
H-11	81-006A-8260	Needle Guide(3/32)	로올러 노루발 바늘안내(3/32)					1		
H-12	81-026A-8260	Needle Guide(1/8)	로올러 노루발 바늘안내(1/8)						1	
H-13	06-011A-8260	Feed Dog(1/8)	톱니(1/8)							1
H-14	06-021A-8260	Feed Dog(1/4)	톱니(1/4)							1
H-15	06-011A-8160	Flat Feed Dog	톱니(평노루발용)							1
H-16	01-025A-8260	Needle Plate(3/64)	침판(3/64)			1				
H-17	01-015A-8260	Needle Plate(1/16)	침판(1/16)				1			
H-18	01-005A-8260	Needle Plate(3/32)	침판(3/32)					1		
H-19	01-035A-8260	Needle Plate(1/8)	침판(1/8)						1	
H-20	01-155A-8260	Needle Plate(1/4)	침판(1/4)							1
H-21	01-015A-8160	Flat Needle Plate	침판(평노루발용)							

수정 리스트 Changed Parts List

No.	Ref. No.	Parts No.	Name of Parts	Contents	Date	Old Parts No.	Remarks
1	A-3	SC-0322-7400	Screw(9/64" n = 40)	Substitution	01. 09	SC-0322-2125	01. 3/4
2	A-6	SC-0502-2302	Screw(9/64" n = 40)	Substitution	01. 09	SC-0502-4125	01. 3/4
3	A-10	SN-0121-7400	Screw(15/64" n = 28)	Substitution	01. 09	SN-0121-4000	01. 3/4
4	A-18	SC-0519-2302	Screw(11/64" n = 40)	Substitution	01. 09	SC-0519-2120	01. 3/4
5	A-20	SC-0519-2302	Screw(11/64" n = 40)	Substitution	01. 09	SC-0519-2120	01. 3/4
6	A-22	SC-0519-2302	Screw(11/64" n = 40)	Substitution	01. 09	SC-0519-2120	01. 3/4
7	A-29	SC-0543-2302	Screw(11/64" n = 40)	Substitution	01. 09	SC-0543-4525	01. 3/4
8	A-31	SC-0501-2302	Screw(11/64" n = 40)	Substitution	01. 09	SC-0501-4120	01. 3/4
9	A-33	SC-0329-8130	Screw(M8×1.25)	Substitution	01. 09	SC-0329-4111	01. 3/4
10	A-38	SC-0348-8130	Screw(M8×1.25)	Substitution	01. 09	SC-0348-4115	01. 3/4
11	A-42	SC-0502-2302	Screw(9/64" n = 40)	Substitution	01. 09	SC-0502-4125	01. 3/4
12	A-45	SC-0543-2302	Screw(11/64" n = 40)	Substitution	01. 09	SC-0543-4525	01. 3/4
13	A-46	SC-0158-3710	Screw(9/64" n = 40)	Substitution	01. 09	SC-0158-4122	01. 3/4
14	A-48	SC-0502-2302	Screw(9/64" n = 40)	Substitution	01. 09	SC-0502-4125	01. 3/4
15	B-1	02-101A-8130	Upper Shaft	Substitution	01. 09	02-001A-8130	01. 3/4
16	B-2	02-002A-8150	Link Cam	Substitution	01. 09	02-002A-8150	01. 3/4
17	B-3	SC-0124-7400	Screw(9/32" n = 28)	Substitution	01. 09	SC-0124-4522	01. 3/4
18	B-4	SC-0123-1230	Screw(9/32" n = 28)	Substitution	01. 09	SC-0123-4422	01. 3/4
19	B-6	02-108A-8130	Upper Shaft Bushing	Substitution	01. 09	02-008A-8130	01. 3/4
20	B-7	SC-0514-7400	Screw(15/64" n = 28)	Substitution	01. 09	SC-0514-4515	01. 3/4
21	B-9	02-121A-1230	Collar For B-11	Substitution	01. 09	02-021A-1230	01. 3/4
22	B-11	02-104A-3400	Upper Shaft Bushing	Substitution	01. 09	02-004A-3400	01. 3/4
23	B-12	SC-0514-7400	Screw(15/64" n = 28)	Substitution	01. 09	SC-0514-4515	01. 3/4
24	B-16	02-105A-3400	Upper Shaft Bushing	Substitution	01. 09	02-005A-3400	01. 3/4
25	B-17	SC-0514-7400	Screw(15/64" n = 28)	Substitution	01. 09	SC-0514-4515	01. 3/4
26	B-21	SC-0150-2500	Screw(15/64" n = 28)	Substitution	01. 09	SC-0150-4122	01. 3/4
27	B-22	SC-0188-1230	Screw(15/64" n = 24)	Substitution	01. 09	SC-0188-4124	01. 3/4
28	B-26	SC-0125-5607	Screw(3/32" n = 56)	Substitution	01. 09	SC-0125-4124	01. 3/4
29	B-29	SC-0160-5607	Needle	Substitution	01. 09	SC-0160-4125	01. 3/4
30	B-30	04-102A-7400	Needle Bar Holder	Substitution	01. 09	04-002A-7400	01. 3/4
31	B-31	SC-0158-3710	Screw(9/64" n = 40)	Substitution	01. 09	SC-0158-4122	01. 3/4
32	B-34	02-104P-7400	Needle Bar Crank Shaft	Substitution	01. 09	02-004P-7400	01. 3/4
33	B-35	SC-0504-1230	Screw(1/4" n = 40)	Substitution	01. 09	SC-0504-4515	01. 3/4
34	B-36	SC-0129-7400	Screw(1/4" n = 40)	Substitution	01. 09	SC-0129-4515	01. 3/4
35	B-40	SC-0497-1230	Screw(3/16" n = 28)	Substitution	01. 09	SC-0498-4122	01. 3/4
36	B-41	04-107A-8260	Needle Bar Bushing	Substitution	01. 09	04-007A-8260	01. 3/4
37	B-42	SC-0114-1230	Screw(15/64" n = 28)	Substitution	01. 09	SC-0114-4515	01. 3/4
38	B-43	04-108A-8260	Needle Bar Bushing	Substitution	01. 09	04-008A-8260	01. 3/4
39	B-44	SC-0114-1230	Screw(15/64" n = 28)	Substitution	01. 09	SC-0114-4515	01. 3/4
40	B-45	02-104A-8270	Thread Take-Up Lever	Substitution	01. 09	02-004-8170	01. 3/4

NOTE)

수정 리스트 Changed Parts List

No.	Ref. No.	Parts No.	Name of Parts	Contents	Date	Old Parts No.	Remarks
41	B-46	02-104A-8270	Thread Take-Up Lever	Substitution	01. 09	02-004A-8270	01. 3/4
42	B-47	08-101A-8130	Hinge Pin For Take-Up Lever	Substitution	01. 09	08-001A-8130	01. 3/4
43	B-48	SC-0514-7400	Screw(15/64" n = 28)	Substitution	01. 09	SC-0514-4515	01. 3/4
44	B-50	02-103A-7400	Take-Up Lever Holder	Substitution	01. 09	02-003A-7400	01. 3/4
45	B-56	SC-0158-3710	Screw(9/64" n = 40)	Substitution	01. 09	SC-0158-4122	01. 3/4
46	B-57-6	SC-0205-3710	Screw(1/4" n = 24)	Substitution	01. 09	SC-0205-4122	01. 3/4
47	B-57-7	SC-0109-2350	Screw(M6)	Substitution	01. 09	SC-0109-4113	01. 3/4
48	C-1	05-101A-8260	Roller Presser Bar	Substitution	01. 09	05-001A-8260	01. 3/4
49	C-2	05-102A-7400	Presser Bar Bushing	Substitution	01. 09	05-*002A-7400	01. 3/4
50	C-3	SC-0114-1230	Screw(15/64" n = 28)	Substitution	01. 09	SC-0114-4515	01. 3/4
51	C-4	05-103A-7400	Presser Bar Holder	Substitution	01. 09	05-003A-400	01. 3/4
52	C-6	05-104A-7400	Presser Bar Bracket	Substitution	01. 09	05-004A-7400	01. 3/4
53	C-14	SC-0158-3710	Screw(9/64" n = 40)	Substitution	01. 09	SC-0158-4122	01. 3/4
54	C-16	SC-0114-1230	Screw(15/64" n = 28)	Substitution	01. 09	SC-0114-4515	01. 3/4
55	C-17-4	SC-0199-2700	Screw(11/64" n = 40)	Substitution	01. 09	SC-0199-4124	01. 3/4
56	C-17-10	SC-0160-5607	Screw(9/64" n = 40)	Substitution	01. 09	SC-0160*4125	01. 3/4
57	C-17-14	SC-0130-1230	Screw(1/8" n = 44)	Substitution	01. 09	SC-0130-4122	01. 3/4
58	C-20	SC-0315-2302	Screw(9/64" n = 40)	Substitution	01. 09	SC-0315-4122	01. 3/4
59	C-30	SC-0128-7400	Screw(11/64" n = 40)	Substitution	01. 09	SC-0128-4118	01. 3/4
60	C-31-4	SC-0542-1230	Screw(11/64" n = 40)	Substitution	01. 09	SC-0542-4515	01. 3/4
61	C-36	SC-0107-1600	Screw(M6×1.0)	Substitution	01. 09	SC-0107-4111	01. 3/4
62	D-1-2	SC-0114-1130	Feed Cam	Substitution	01. 09	SC-0114-4515	01. 3/4
63	D-2	06-102A-3400	Screw(15/64" n = 28)	Substitution	01. 09	06-002A-3400	01. 3/4
64	D-7	SN-0107-1230	Nut(9/32" n = 28)	Substitution	01. 09	SN-0107-4000	01. 3/4
65	D-8	06-131A-1230	Feed Link	Substitution	01. 09	06-031A-1230	01. 3/4
66	D-10	SC-0122-1230	Screw(15/64" n = 28)	Substitution	01. 09	SC-0122-4522	01. 3/4
67	D-11	06-104A-8130	Feed Regulator	Substitution	01. 09	06-004A-8130	01. 3/4
68	D-12	06-109A-3400	Feed Regulator Bushing	Substitution	01. 09	06-009A-3400	01. 3/4
69	D-13	SC-0122-1230	Screw(15/64" n = 28)	Substitution	01. 09	SC-0122-4522	01. 3/4
70	D-14	06-110A-3400	Feed Regulator Bushing	Substitution	01. 09	06-010A-3400	01. 3/4
71	D-15	SC-0517-1230	Screw(15/64" n = 28)	Substitution	01. 09	SC-0507-4515	01. 3/4
72	D-18	SC-0193-1230	Screw(3/16" n = 28)	Substitution	01. 09	SC-0193-4122	01. 3/4
73	D-21	06-107A-8130	Feed Rock Shaft Crank	Substitution	01. 09	06-007A-8130	01. 3/4
74	D-23	SC-0543-2302	Screw(11/64" n = 40)	Substitution	01. 09	SC-0543-4525	01. 3/4
75	D-24	SC-0497-1230	Screw(3/16" n = 28)	Substitution	01. 09	SC-0497-4122	01. 3/4
76	D-25	06-123A-1230	Feed Rock Shaft	Substitution	01. 09	06-023A-1230	01. 3/4
77	D-27	SC-0114-1230	Screw(15/64" n = 28)	Substitution	01. 09	SC-0114-4515	01. 3/4
78	D-29	SC-0114-1230	Screw(15/64" n = 28)	Substitution	01. 09	SC-0114-4515	01. 3/4
79	D-31	SC-0307-1230	Screw(3/16" n = 32)	Substitution	01. 09	SC-0307-4122	01. 3/4
80	D-32	06-109A-1230	Feed Bar Shaft	Substitution	01. 09	06-009A-4122	01. 3/4

NOTE)

수정 리스트 Changed Parts List

No.	Ref. No.	Parts No.	Name of Parts	Contents	Date	Old Parts No.	Remarks
81	D-35	06-110A-3400	Feed Bar	Substitution	01. 09	06010A-8130	01. 3/4
82	D-37	SC-0128-7400	Screw(11/64" n = 40)	Substitution	01. 09	SC-0128-4118	01. 3/4
83	D-40	06-129A-3400	Feed Lifting Shaft Crank	Substitution	01. 09	06-029A-3400	01. 3/4
84	D-41	SC-0497-1230	Screw(3/16" n = 28)	Substitution	01. 09	SC-0497-4122	01. 3/4
85	D-42	06-111A-8130	Feed Lifting Shaft	Substitution	01. 09	06-011A-8130	01. 3/4
86	D-43	SC-0360-3400	Screw(3/8" n = 28)	Substitution	01. 09	SC-0360-4415	01. 3/4
87	D-45	SC-0358-8130	Screw(3/8" n = 28)	Substitution	01. 09	SC-0358-4415	01. 3/4
88	D-48	SN-0107-1230	Nut(9/32" n = 28)	Substitution	01. 09	SN-0107-4000	01. 3/4
89	D-49	06-113A-8130	Crank Rod	Substitution	01. 09	06-013A-8130	01. 3/4
90	D-52-5	SC-0184-1600	Screw(3/16" n = 28)	Substitution	01. 09	SC-0184-4118	01. 3/4
91	D-54	SC-0307-1230	Screw(3/16" n = 32)	Substitution	01. 09	SC-0307-4122	01. 3/4
92	D-57	06-114A-8130	Reverse Lever Shaft	Substitution	01. 09	06-014A-8130	01. 3/4
93	D-60	SC-0185-1230	Screw(3/16" n = 32)	Substitution	01. 09	SC-0185-4124	01. 3/4
94	D-61	SC-0186-1230	Screw(3/16" n = 32)	Substitution	01. 09	SC-0186-4118	01. 3/4
95	E-1	03-101A-8130	Upright Shaft	Substitution	01. 09	03-001A-8130	01. 3/4
96	E-3	03-102A-3400	Upright Shaft Bushing	Substitution	01. 09	03-002A-3400	01. 3/4
97	E-4	SC-0507-1230	Screw(15/64" n = 28)	Substitution	01. 09	SC-0507-4515	01. 3/4
98	E-7	03-102A-8130	Upright Shaft Bushing	Substitution	01. 09	03-002A-8130	01. 3/4
99	E-8	SC-0507-1230	Screw(15/64" n = 28)	Substitution	01. 09	SC-0507-4515	01. 3/4
100	E-11	03-103A-8130	Upright Shaft Bushing	Substitution	01. 09	03-003A-8130	01. 3/4
101	E-12	SC-0507-1230	Screw(15/64" n = 28)	Substitution	01. 09	SC-0507-4515	01. 3/4
102	E-16	07-101A-8130	Lower Shaft	Substitution	01. 09	07-001A-8130	01. 3/4
103	E-18	SC-0507-1230	Screw(15/64" n = 28)	Substitution	01. 09	SC-0507-4515	01. 3/4
104	E-21	08-103A-8130	Lower Shaft Bushing	Substitution	01. 09	08-003A-8130	01. 3/4
105	E-22	SC-0507-1230	Screw(15/64" n = 28)	Substitution	01. 09	SC-0507-4515	01. 3/4
106	E-23	44-119A-1230	Collar For E-16	Substitution	01. 09	44-019A-1230	01. 3/4
107	E-24	SC-0542-1230	Screw(11/64" n = 40)	Substitution	01. 09	SC-0542-4515	01. 3/4
108	E-25	08-104A-8130	Lower Shaft Bushing	Substitution	01. 09	08-004A-8130	01. 3/4
109	E-26	SC-0507-1230	Screw(15/64" n = 28)	Substitution	01. 09	SC-0507-4515	01. 3/4
110	E-30-6	SC-0205-3710	Screw(1/4" n = 24)	Substitution	01. 09	SC-0205-4122	01. 3/4
111	E-32	SC-0184-1600	Screw(3/64" n = 28)	Substitution	01. 09	SC-0184-4118	01. 3/4
112	F-1	09-105A-8130	Post	Substitution	01. 09	09-005A-8130	01. 3/4
113	F-2	09-101A-8230	Post	Substitution	01. 09	09-001A-8230	01. 3/4
114	F-3	SC-0344-8260	Screw(15/64" n = 24)	Substitution	01. 09	SC-0344-4125	01. 3/4
115	F-4	SC-0253-7400	Screw(15/64" n = 24)	Substitution	01. 09	SC-0253-4118	01. 3/4
116	G-9	09-130A-7400	Bobbin	Substitution	01. 09	09-030A-7400	01. 3/4
117	A-11	44-101A-8130	Oil Tank	Substitution	02. 06	44-001A-8130	01. 3/4
118	A-15	44-108A-8130	Oil Tank Cover	Substitution	02. 06	01-008A-8130	01. 3/4
119	A-26	01-110A-8130	Upper Shaft Collar Cover	Substitution	02. 06	01-010A-8130	01. 3/4
120	C-11	01-116G-8130	Presser Bar Plate Spring	Substitution	02. 06	05-016G-8130	02. 2/4

NOTE)

수정 리스트
Changed Parts List

No.	Ref. No.	Parts No.	Name of Parts	Contents	Date	Old Parts No.	Remarks
121	C-17-1	81-104A-8260	Roller Presser Bracket	Substitution	02. 06	81-004A-8260	02. 2/4
122	C-25	43-101A-8130	Connecting Link For C-21	Substitution	02. 06	43-001A-8130	02. 2/4
123	D-53	06-135C-1230	Upper Spring Holder	Substitution	02. 06	06-035C-2350	02. 2/4
124	F-27	09-123C-8170	Post Right Cover	Substitution	02. 06	09-023C-8170	02. 2/4
125	F-28	09-124C-8130	Post Right Cover	Substitution	02. 06	08-024C-8170	02. 2/4
126	F-52	09-130A-7400	Bobbin	Substitution	02. 06	09-030A-7400	02. 2/4
127	G-32	60-101A-8130	Belt Cover Ass'y	Additional Part	02. 06		02. 2/4
128	G-32-1	60-001A-8130	Belt Cover	Additional Part	02. 06		02. 2/4
129	G-32-2	60-006P-8670	Support Pin For Belt Cover	Additional Part	02. 06		02. 2/4
130	G-32-3	01-016R-2700	Stopper For Belt Cover	Additional Part	02. 06		02. 2/4
131	G-32-4	SC-0543-2302	Screw For Belt Cover	Additional Part	02. 06		02. 2/4
132	H-6	05-017A-8150	Roller Presser	Substitution	02. 06	81-011A-8260	02. 2/4
133	H-7		Roller Presser	Deleted Part	02. 06	81-001A-8260	02. 2/4
134							
135							
136							
137							
138							
139							
140							
141							
142							
143							
144							
145							
146							
147							
148							
149							
150							
151							
152							
153							
154							
155							
156							
157							
158							
159							
160							

NOTE)

**SUNSTAR MACHINERY CO., LTD.****HEAD OFFICE**

178-212, GAJWA-DONG, SEO-KU, INCHON, KOREA
 TEL : (032) 580 - 5600 ~ 4 FAX : (032) 584 - 3020

TRADE OFFICE

178-212, GAJWA-DONG, SEO-KU, INCHON, KOREA
 TEL : (032) 580 - 5740 ~ 60 FAX : (032) 584 - 3025 ~ 6

OVERSEAS NETWORK**SUNSTAR MACHINERY U.S.A., INC.**

11475. N.W. 39TH ST. Miami, Florida 33178, USA
 TEL : 1-305-591-9596 FAX : 1-305-591-0661

SUNSTAR MACHINERY HONGKONG LTD.

RM. 1302, Apec Plaza, No. 49 Hoi Yuen RD,
 Kwun Tong, Kln. H. K.
 TEL : 852-2729-7078, 852-2729-7224 FAX : 852-2729-7573

SUNSTAR MACHINERY SHANG HAI LTD. (CHINA)

#7 Yuangong Rd. Shanghai International Automobiles City
 Components Sub-Assembly Industrial Zone Jiading Shanghai China
 TEL : 86-21-69576305, 69576306 FAX : 86-21-69576091, 69576093

SUNSTAR MACHINERY GUANG DONG BRANCH (CHINA)

Luosha Daxia 12TH Floor 170 Dong Xing-Road, Dong Guan
 Shicheng Qu, Guang Dong, China
 TEL : 86-769-249-1610 FAX : 86-769-234-4042

SUNSTAR MACHINERY FUJIAN BRANCH (CHINA)

504, Agricultural Bank Building Shishi Fujian, China
 TEL : 86-595-859-8871 FAX : 86-595-859-8872

SUNSTAR MACHINERY QINGDAO BRANCH (CHINA)

Chengyangqu Liutingzhen Chongyanglu Shoufeizhan
 Beiduan Shangpinlou Qingdao Shandong, China
 TEL : 86-532-482-2236, 86-532-481-1262 FAX : 86-532-481-1262

SUNSTAR MACHINERY JAKARTA BRANCH

JL. Pelepah Indah Raya Bloc LC 2/2 Kelapa Gading Permai
 Jakarta(14250) Indonesia
 TEL : 62-21-450-2143, 62-21-4584-0752 FAX : 62-21-4584-0214

SUNSTAR MACHINERY HOCHIMINH BRANCH (VIETNAM)

#E23 Nguyen Thai Binh ST. W. 12 Tan Binh District,
 Hochiminh City, Vietnam
 TEL : 84-8-811-4141 FAX : 84-8-811-4588

SUNSTAR MACHINERY HANOI BRANCH (VIETNAM)

19 Son Tay. W. Dien Bien Ba Dinh Dist., Hanoi, Vietnam
 TEL : 84-4-734-0268 FAX : 84-4-734-0278

WEB-SITE

<http://www.sunstar.co.kr>

E-MAIL

sunstar@sunstar.co.kr
swf@sunstar.co.kr
fortuna@sunstar.co.kr



По вопросам приобретения или с целью консультации
вы можете обращаться по телефону: (495) 989-22-97
или по e-mail: info@krung.ru

Также предлагаем вам посетить
наш информационный сайт
www.krung.ru